



BS&B SAFETY SYSTEMS, L.L.C.

SPECIAL ENGINEERING INSTRUCTIONS

DRAWN BY Kunwarani NO. II-MR-0031
 CHK'D. BY SIRISH DATE 9-22-11 SHEET 1 OF 32
 APP. BY Chuk Beau REVISION 0 RELEASE NO. 11-T-0500

| | | | | |
|---------|--------------------|------------------|-------------------|-----------------|
| REV.: D | ECN NO.: 17-T-0107 | DRAWN: Kunwarani | CHK'D.: Vasanthan | DATE: 03-Apr-17 |
|---------|--------------------|------------------|-------------------|-----------------|

"PROPRIETARY DATA" IS INCLUDED IN THE INFORMATION DISCLOSED HEREIN AND IS THE SOLE PROPERTY OF BS&B PRESSURE SAFETY MANAGEMENT, L.L.C. THIS INFORMATION IS SUBMITTED IN CONFIDENCE AND NEITHER THIS DOCUMENT NOR THE INFORMATION DISCLOSED HEREIN SHALL BE REPRODUCED OR TRANSFERRED TO OTHER DOCUMENTS OR DISCLOSED TO OTHERS FOR MANUFACTURING OR FOR ANY OTHER PURPOSE EXCEPT AS SPECIFICALLY AUTHORIZED IN WRITING BY BS&B PRESSURE SAFETY MANAGEMENT, L.L.C. US AND INTERNATIONAL PATENTS PENDING.

INSTALLATION, OPERATION AND MAINTENANCE INSTRUCTIONS FOR M 4.2K BACK PRESSURE INDEPENDENT VALVE (BPIV)

Sales Order No.: _____

Serial No.: _____ Tag No.: _____

Valve Assembly No.: _____ Main Seal Part No.: _____

Size: _____ Approved by: _____ Date: _____

**Maximum opening, closing and rotational torques are to be recorded in the
 Torque maintenance Instructions included herein.
 This document is to be shipped with valve and a copy included in the sales file.**



SPECIAL ENGINEERING INSTRUCTIONS

DRAWN BY Kunwarani NO. II-MR-0031
CHK'D. BY SIRISH DATE 9-22-11 SHEET 2 OF 32
APP. BY Chank Beain REVISION 0 RELEASE NO. 11-T-0500

| | | | | | | | | | |
|-------|---|----------|-----------|--------|-----------|---------|----------------|-------|-----------|
| REV.: | D | ECN NO.: | 17-T-0107 | DRAWN: | Kunwarani | CHK'D.: | Vasanthakumari | DATE: | 03-Apr-17 |
|-------|---|----------|-----------|--------|-----------|---------|----------------|-------|-----------|

"PROPRIETARY DATA" IS INCLUDED IN THE INFORMATION DISCLOSED HEREIN AND IS THE SOLE PROPERTY OF BS&B PRESSURE SAFETY MANAGEMENT, L.L.C. THIS INFORMATION IS SUBMITTED IN CONFIDENCE AND NEITHER THIS DOCUMENT NOR THE INFORMATION DISCLOSED HEREIN SHALL BE REPRODUCED OR TRANSFERRED TO OTHER DOCUMENTS OR DISCLOSED TO OTHERS FOR MANUFACTURING OR FOR ANY OTHER PURPOSE EXCEPT AS SPECIFICALLY AUTHORIZED IN WRITING BY BS&B PRESSURE SAFETY MANAGEMENT, L.L.C. US AND INTERNATIONAL PATENTS PENDING.

INSTALLATION INSTRUCTIONS

BACK PRESSURE INDEPENDENT VALVE (BPIV)

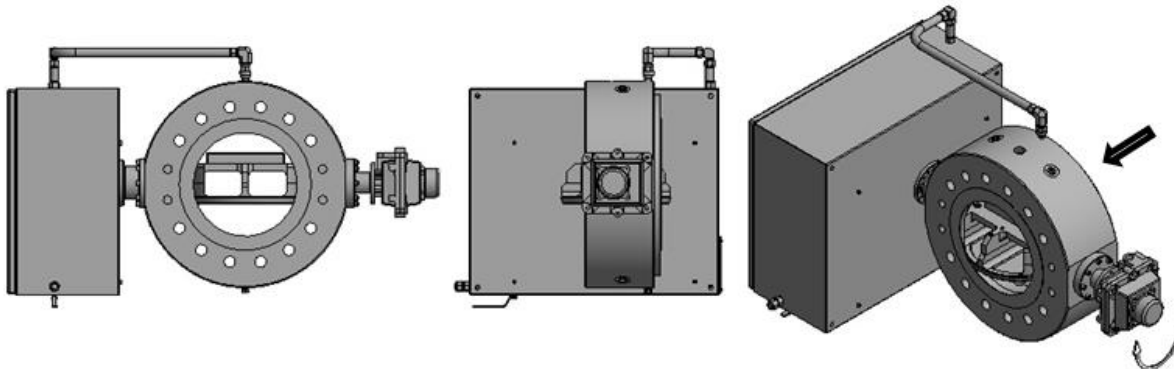

Image – 1: Valve assembly

US Patents 5,947,445; 5,984,269 and International Patents apply

Danger: BPIV's are intended to provide a pressure relief opening. The BPIV is designed to instantaneously open at a specified temperature and pressure, thereby relieving excess pressure or preventing excessive vacuum in a system. **IT IS IMPERATIVE THAT THIS BPIV BE PROPERLY INSTALLED AND SAFELY VENTED IN ORDER TO AVOID BODILY INJURY, DAMAGE TO PROPERTY, POLLUTION AND LOSS OF PRODUCT.**

BS&B Pressure Safety Management, L.L.C. supply BPIV's selected by their customers, which are manufactured in reliance upon information and specifications supplied by the customer. BS&B Pressure Safety Management, L.L.C. is not liable for any damage resulting from improper installation, improper system design, unsafe venting, or other factors beyond BS&B Pressure Safety Management, L.L.C. control.



SPECIAL ENGINEERING INSTRUCTIONS

DRAWN BY Kunwarani NO. II-MR-0031
CHK'D. BY SIRISH DATE 9-22-11 SHEET 3 OF 32
APP. BY Chuk Beau REVISION 0 RELEASE NO. 11-T-0500

| | | | | |
|---------|--------------------|------------------|-------------------|-----------------|
| REV.: D | ECN NO.: 17-T-0107 | DRAWN: Kunwarani | CHK'D.: Vasanthan | DATE: 03-Apr-17 |
|---------|--------------------|------------------|-------------------|-----------------|

"PROPRIETARY DATA" IS INCLUDED IN THE INFORMATION DISCLOSED HEREIN AND IS THE SOLE PROPERTY OF BS&B PRESSURE SAFETY MANAGEMENT, L.L.C. THIS INFORMATION IS SUBMITTED IN CONFIDENCE AND NEITHER THIS DOCUMENT NOR THE INFORMATION DISCLOSED HEREIN SHALL BE REPRODUCED OR TRANSFERRED TO OTHER DOCUMENTS OR DISCLOSED TO OTHERS FOR MANUFACTURING OR FOR ANY OTHER PURPOSE EXCEPT AS SPECIFICALLY AUTHORIZED IN WRITING BY BS&B PRESSURE SAFETY MANAGEMENT, L.L.C. US AND INTERNATIONAL PATENTS PENDING.

SAFETY PRECAUTIONS:

- Caution:** Provide adequate support for the piping and the connections to absorb recoil/reaction forces when the BPIV opens. If the discharge is free vented, a baffle plate may be mounted downstream of the outlet companion pipe flange with extra length studs to minimize recoil.
- Caution:** The BPIV valve should not be subjected to bending stresses such as those developed by misaligned piping, unsupported piping or improper torque application to companion flange. Mating flange faces shall be parallel to BPIV flanges.
- Caution:** Do not locate the BPIV where it may be subjected to thermal shock. Review any concerns with BS&B Pressure Safety Management, L.L.C. before installation.
- Caution:** Corrosion and process conditions may cause deterioration and necessitate periodic inspection and/or replacement of component parts.
- Caution:** When the BPIV opens, a pressure shock wave is generated. Take account of the affect this may have on the operating performance of downstream and upstream equipment.
- Caution:** When the BPIV opens, the rotating disc will extend beyond the body on both the inlet & outlet sides. Make sure that the disc cannot contact upstream or downstream components; this will affect the opening of the BPIV. Make sure that the fully opened disc does not project into an adjacent flow path that will load the disc and risk damage of the BPIV.
- Caution:** Each BPIV is designed and tested for use in a specific orientation, such as vertical flow up, vertical flow down, horizontal flow with the valve-opening bottom up or horizontal flow with the valve opening top down. Install your BPIV in this orientation. Consult BS&B before changing orientation; retesting by BS&B is probably required. Test certificates and "Code Stamping" is void when a BPIV is applied in the wrong orientation.
- Warning:** Do not locate the BPIV where personnel will be exposed to released product and pressure through the BPIV.

BEFORE YOU INSTALL THE BPIV VALVE

Handling Instructions

1. Never lift or move the valve assembly using the plug, valve seat (bore), or shafts as lifting points.
2. Never lift or move the valve assembly by using the mechanism, sensor, or other attached accessories.
3. Valve should be handled gently and any rough handling of the valve should be avoided which could disturb the Mechanism settings.



BS&B SAFETY SYSTEMS, L.L.C.

SPECIAL ENGINEERING INSTRUCTIONS

DRAWN BY Kunwarani NO. II-MR-0031
CHK'D. BY SIRISH DATE 9-22-11 SHEET 4 OF 32
APP. BY Chuck Beain REVISION 0 RELEASE NO. 11-T-0500

| | | | | | | | | | |
|-------|---|----------|-----------|--------|-----------|---------|-----------|-------|-----------|
| REV.: | D | ECN NO.: | 17-T-0107 | DRAWN: | Kunwarani | CHK'D.: | Vasanthan | DATE: | 03-Apr-17 |
|-------|---|----------|-----------|--------|-----------|---------|-----------|-------|-----------|

"PROPRIETARY DATA" IS INCLUDED IN THE INFORMATION DISCLOSED HEREIN AND IS THE SOLE PROPERTY OF BS&B PRESSURE SAFETY MANAGEMENT, L.L.C. THIS INFORMATION IS SUBMITTED IN CONFIDENCE AND NEITHER THIS DOCUMENT NOR THE INFORMATION DISCLOSED HEREIN SHALL BE REPRODUCED OR TRANSFERRED TO OTHER DOCUMENTS OR DISCLOSED TO OTHERS FOR MANUFACTURING OR FOR ANY OTHER PURPOSE EXCEPT AS SPECIFICALLY AUTHORIZED IN WRITING BY BS&B PRESSURE SAFETY MANAGEMENT, L.L.C. US AND INTERNATIONAL PATENTS PENDING.

Lifting Instructions

1. Shoulderless eye bolts should be used only where the hoist chain or sling is aligned with the axis of the bolt, so that it pulls in exactly the same direction as the shaft of the bolt. The bolt must be fully screwed into the valve body. If the chain or sling pulls at an angle to the axis of the eye bolt, the bolt may snap. It is recommended that forged steel material be used for eye bolts.
2. Shouldered eye bolts must be used whenever the chain or sling is rigged at an angle from the axis of the bolt. The eye bolt must be screwed into the valve body until the shoulder fits flat and tight against the surface of the counter bore in valve body. To make sure the eye bolt will not be bent sideways, the chain or sling must be in the plane of the eye of the eyebolt. To ensure that the shoulder is firmly seated on the surface of the load when the eye has been correctly aligned with the chain or sling, a metal washer of suitable size and shape may be used under the shoulder. The depth of thread engagement must be at least 1.5 times the diameter of the eye bolt shaft. It is recommended that forged steel material be used for eye bolts.
3. In any situation where there is doubt about the safety of using eye bolts, it is recommended that swivel hoist rings be used instead of eye bolts. Follow manufacturing recommendations in selecting and using these rings.
4. Never over-torque a lifting device. Never use a lifting device that has bad threads. Never use a lifting device that is corroded, cracked, bent, twisted, stretched, fatigued, undersized, or questionable.
5. Valves shall always be lifted vertically up using the recommended eye bolts shown in the approval drawings.
6. While lifting the valve use a single lift point with 2 straps or 2 chains that are equal in length. See Fig 1 strap A is equal in length to strap B. The length of straps need to be long enough so θ is greater than 50° . COG details are given on the approval drawings.
7. Any slings, chains, lifting beams, spreaders or other necessary equipment shall be certified to lift the equipment weight plus a margin of 50%.
8. It is recommended that lifting straps be used thru the eye bolts or chains with hooks with safety latches.
9. Some of Dos and Don'ts for lifting the valve assembly are shown in figures 1 thru 4.
10. Angle of lift (θ) should be 50° or more.



SPECIAL ENGINEERING INSTRUCTIONS

DRAWN BY Kunwarani NO. II-MR-0031
 CHK'D. BY SIRISH DATE 9-22-11 SHEET 5 OF 32
 APP. BY Chuk Beav REVISION 0 RELEASE NO. 11-T-0500

| | | | | |
|---------|--------------------|------------------|-------------------|-----------------|
| REV.: D | ECN NO.: 17-T-0107 | DRAWN: Kunwarani | CHK'D.: Vasanthan | DATE: 03-Apr-17 |
|---------|--------------------|------------------|-------------------|-----------------|

"PROPRIETARY DATA" IS INCLUDED IN THE INFORMATION DISCLOSED HEREIN AND IS THE SOLE PROPERTY OF BS&B PRESSURE SAFETY MANAGEMENT, L.L.C. THIS INFORMATION IS SUBMITTED IN CONFIDENCE AND NEITHER THIS DOCUMENT NOR THE INFORMATION DISCLOSED HEREIN SHALL BE REPRODUCED OR TRANSFERRED TO OTHER DOCUMENTS OR DISCLOSED TO OTHERS FOR MANUFACTURING OR FOR ANY OTHER PURPOSE EXCEPT AS SPECIFICALLY AUTHORIZED IN WRITING BY BS&B PRESSURE SAFETY MANAGEMENT, L.L.C. US AND INTERNATIONAL PATENTS PENDING.

Recommended Lifting method for smaller size valves.

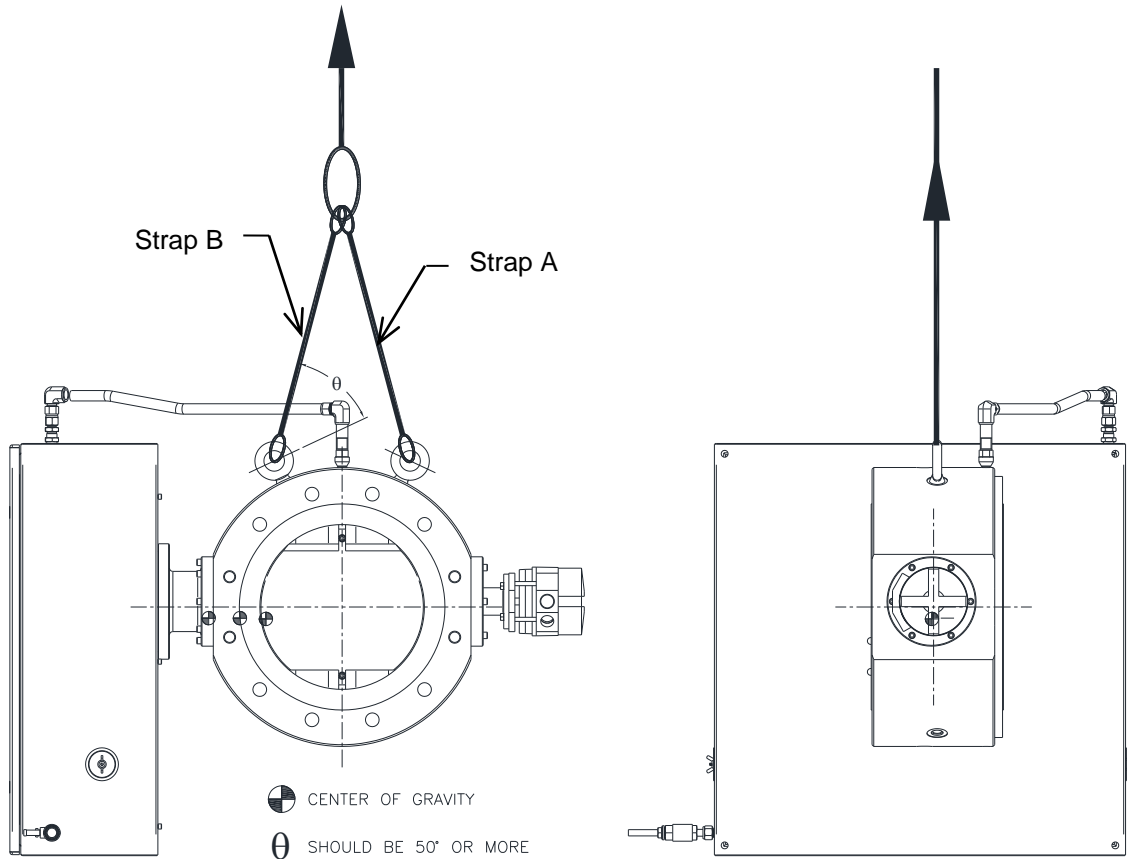

Figure 1: DO'S for BPIV (Typ)

Note: Smaller valves where Center of Gravity (COG) is considerably off center due to mechanism weight and extended spindle shafts for cryo valves.



BS&B SAFETY SYSTEMS, L.L.C.

SPECIAL ENGINEERING INSTRUCTIONS

DRAWN BY Kunwarani NO. II-MR-0031
 CHK'D. BY SIRISH DATE 9-22-11 SHEET 6 OF 32
 APP. BY Chand Beain REVISION 0 RELEASE NO. 11-T-0500

| | | | | |
|---------|--------------------|------------------|-------------------|-----------------|
| REV.: D | ECN NO.: 17-T-0107 | DRAWN: Kunwarani | CHK'D.: Vasanthan | DATE: 03-Apr-17 |
|---------|--------------------|------------------|-------------------|-----------------|

"PROPRIETARY DATA" IS INCLUDED IN THE INFORMATION DISCLOSED HEREIN AND IS THE SOLE PROPERTY OF BS&B PRESSURE SAFETY MANAGEMENT, L.L.C. THIS INFORMATION IS SUBMITTED IN CONFIDENCE AND NEITHER THIS DOCUMENT NOR THE INFORMATION DISCLOSED HEREIN SHALL BE REPRODUCED OR TRANSFERRED TO OTHER DOCUMENTS OR DISCLOSED TO OTHERS FOR MANUFACTURING OR FOR ANY OTHER PURPOSE EXCEPT AS SPECIFICALLY AUTHORIZED IN WRITING BY BS&B PRESSURE SAFETY MANAGEMENT, L.L.C. US AND INTERNATIONAL PATENTS PENDING.

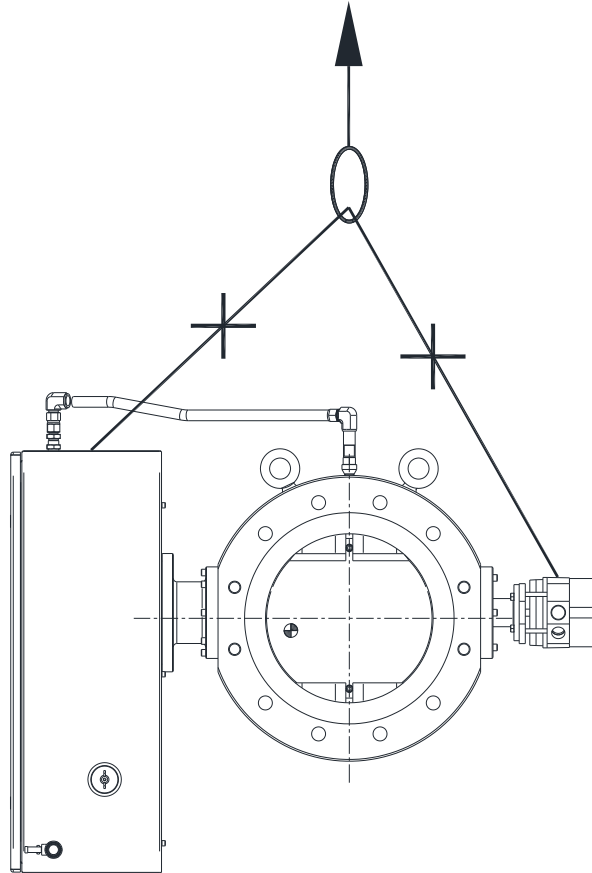

Figure 2: DONT'S for BPIV (Typ)

Note: Mechanism or Sensor **MUST NOT** be strapped for lifting Valves.



BS&B SAFETY SYSTEMS, L.L.C.

SPECIAL ENGINEERING INSTRUCTIONS

DRAWN BY Kunwarani NO. II-MR-0031
 CHK'D. BY SIRISH DATE 9-22-11 SHEET 7 OF 32
 APP. BY Chand Beain REVISION 0 RELEASE NO. 11-T-0500

| | | | | |
|---------|--------------------|------------------|-------------------|-----------------|
| REV.: D | ECN NO.: 17-T-0107 | DRAWN: Kunwarani | CHK'D.: Vasudevan | DATE: 03-Apr-17 |
|---------|--------------------|------------------|-------------------|-----------------|

"PROPRIETARY DATA" IS INCLUDED IN THE INFORMATION DISCLOSED HEREIN AND IS THE SOLE PROPERTY OF BS&B PRESSURE SAFETY MANAGEMENT, L.L.C. THIS INFORMATION IS SUBMITTED IN CONFIDENCE AND NEITHER THIS DOCUMENT NOR THE INFORMATION DISCLOSED HEREIN SHALL BE REPRODUCED OR TRANSFERRED TO OTHER DOCUMENTS OR DISCLOSED TO OTHERS FOR MANUFACTURING OR FOR ANY OTHER PURPOSE EXCEPT AS SPECIFICALLY AUTHORIZED IN WRITING BY BS&B PRESSURE SAFETY MANAGEMENT, L.L.C. US AND INTERNATIONAL PATENTS PENDING.

Recommended Lifting method for Bigger size valves

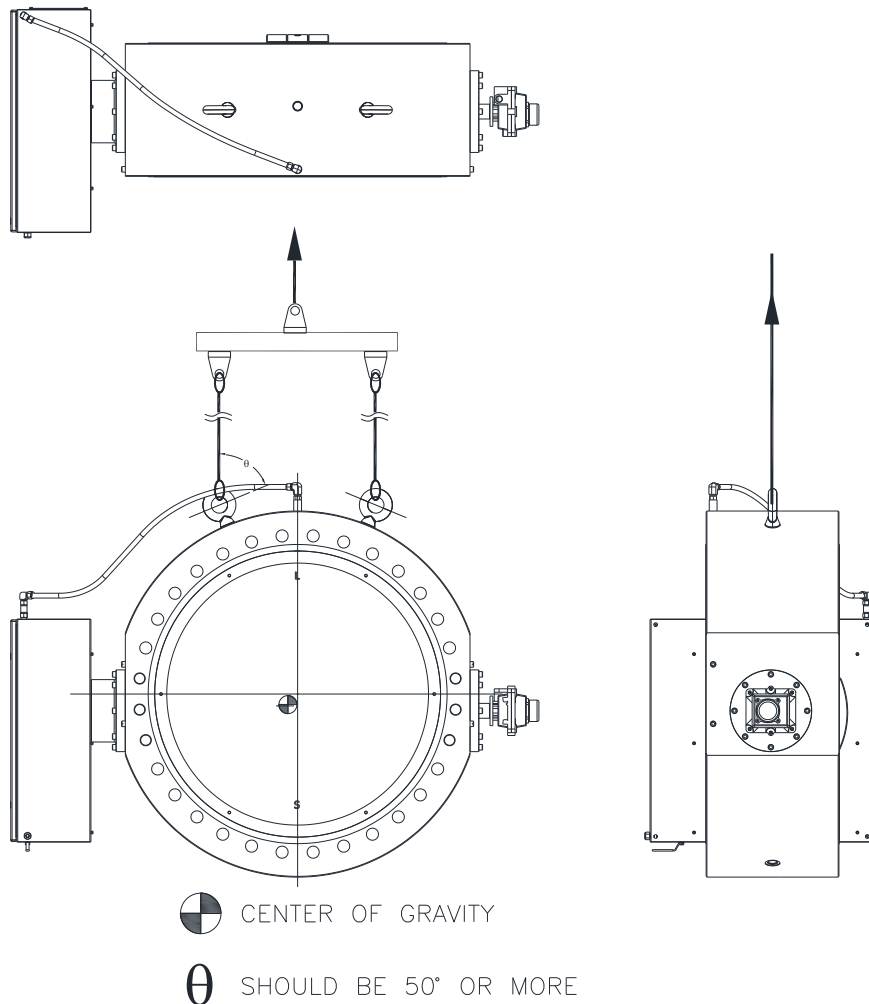

Figure 3: DO'S for BPIV (Typ)

Note: Larger valves where COG is closer to the center of the valve due to the heavy weight of the valve body that offsets mechanism weight.



SPECIAL ENGINEERING INSTRUCTIONS

DRAWN BY Kunwarani NO. II-MR-0031
CHK'D. BY SIRISH DATE 9-22-11 SHEET 8 OF 32
APP. BY Chand Beain REVISION 0 RELEASE NO. 11-T-0500

| | | | | |
|---------|--------------------|------------------|-------------------|-----------------|
| REV.: D | ECN NO.: 17-T-0107 | DRAWN: Kunwarani | CHK'D.: Vasanthan | DATE: 03-Apr-17 |
|---------|--------------------|------------------|-------------------|-----------------|

"PROPRIETARY DATA" IS INCLUDED IN THE INFORMATION DISCLOSED HEREIN AND IS THE SOLE PROPERTY OF BS&B PRESSURE SAFETY MANAGEMENT, L.L.C. THIS INFORMATION IS SUBMITTED IN CONFIDENCE AND NEITHER THIS DOCUMENT NOR THE INFORMATION DISCLOSED HEREIN SHALL BE REPRODUCED OR TRANSFERRED TO OTHER DOCUMENTS OR DISCLOSED TO OTHERS FOR MANUFACTURING OR FOR ANY OTHER PURPOSE EXCEPT AS SPECIFICALLY AUTHORIZED IN WRITING BY BS&B PRESSURE SAFETY MANAGEMENT, L.L.C. US AND INTERNATIONAL PATENTS PENDING.

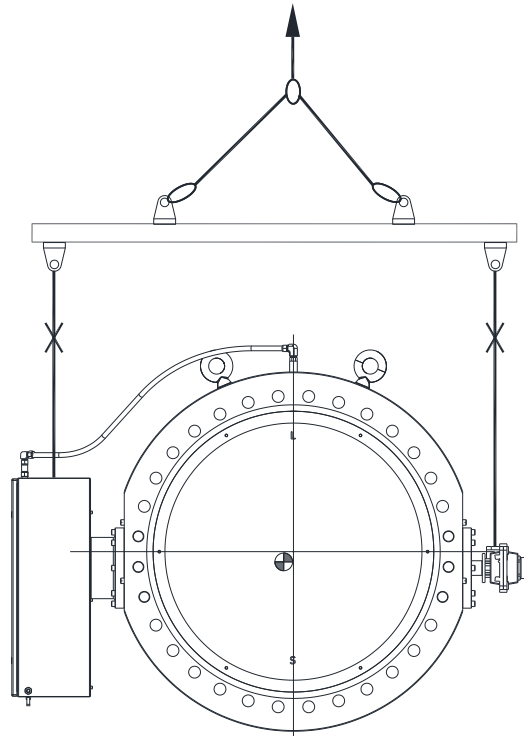

Figure 4: DONT'S for BPIV (Typ)

Note: Mechanism or Sensor **MUST NOT** be strapped for lifting Valves.

Inspect the BPIV Valve

1. Inspect the BPIV valve mating surfaces for foreign materials. Dirt or grit can cause the companion flange gaskets to not seal properly and leak.
2. Do not open mechanism box prior to installation of BPIV in piping system. Inspect the outside of mechanism box for damage. If any physical damage is detected, contact BS&B Pressure Safety Management, L.L.C. Damage to the mechanisms could cause the valve to open at a pressure other than the rated pressure.
3. If mechanism box is opened for any reason, do not remove the "Red Shipping Pin" and "Red Trigger Stop Spacer" from the mechanism. The "Red Shipping Pin" and "Red Trigger Stop Spacer" will be appropriately marked and installed in mechanism. Refer image 2. Note: "Red Shipping Pin" and "Red Trigger Stop Spacer" are two (2) pieces that work together to prevent the trigger from kicking out and plug opening during shipping and handling.
4. The BPIV valve size and rating must match the size and rating of the companion flange.



SPECIAL ENGINEERING INSTRUCTIONS

DRAWN BY Kunwarani NO. II-MR-0031
 CHK'D. BY SIRISH DATE 9-22-11 SHEET 9 OF 32
 APP. BY Chuck Beain REVISION 0 RELEASE NO. 11-T-0500

| | | | | |
|---------|--------------------|------------------|-------------------|-----------------|
| REV.: D | ECN NO.: 17-T-0107 | DRAWN: Kunwarani | CHK'D.: Vasudevan | DATE: 03-Apr-17 |
|---------|--------------------|------------------|-------------------|-----------------|

"PROPRIETARY DATA" IS INCLUDED IN THE INFORMATION DISCLOSED HEREIN AND IS THE SOLE PROPERTY OF BS&B PRESSURE SAFETY MANAGEMENT, L.L.C. THIS INFORMATION IS SUBMITTED IN CONFIDENCE AND NEITHER THIS DOCUMENT NOR THE INFORMATION DISCLOSED HEREIN SHALL BE REPRODUCED OR TRANSFERRED TO OTHER DOCUMENTS OR DISCLOSED TO OTHERS FOR MANUFACTURING OR FOR ANY OTHER PURPOSE EXCEPT AS SPECIFICALLY AUTHORIZED IN WRITING BY BS&B PRESSURE SAFETY MANAGEMENT, L.L.C. US AND INTERNATIONAL PATENTS PENDING.

- If the BPIV has a rust preventative applied, clean with an appropriate solvent, such as MEK.
- The BPIV valve must not be machined or modified in any way except with the approval of BS&B Pressure Safety Management, L.L.C. Failure to obtain such approval voids the warranty on this product.

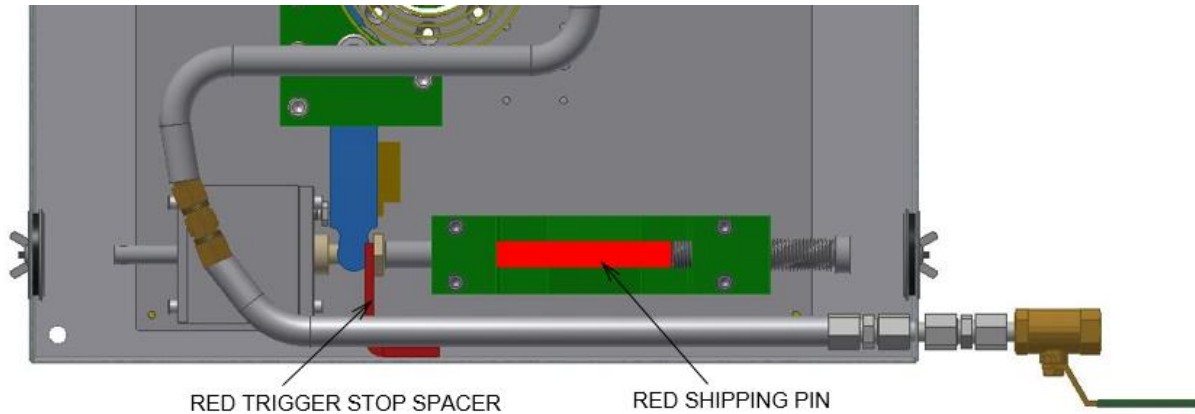

Image – 2(clock spring): Direct Buckling Mechanism with Red Shipping Pin and Red Trigger Stop Spacer

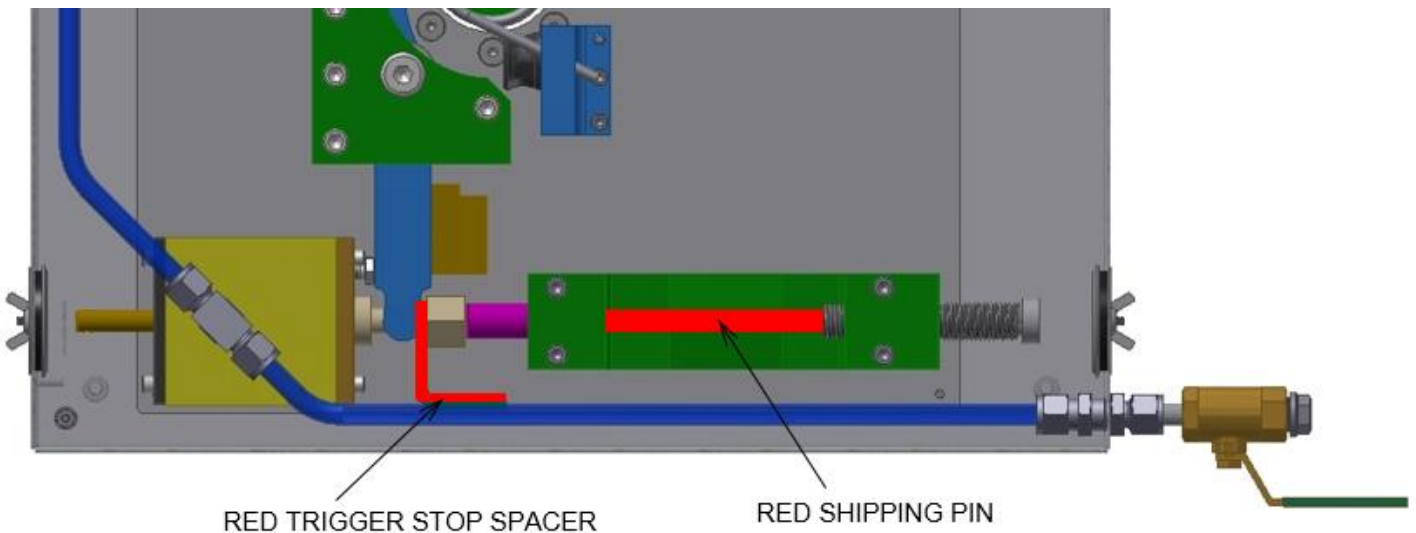

Image – 2(Alternate) (torsion spring): Direct Buckling Mechanism with Red Shipping Pin and Red Trigger Stop Spacer



BS&B SAFETY SYSTEMS, L.L.C.

SPECIAL ENGINEERING INSTRUCTIONS

DRAWN BY Kunwarani NO. II-MR-0031
CHK'D. BY SIRISH DATE 9-22-11 SHEET 10 OF 32
APP. BY Chuck Bean REVISION 0 RELEASE NO. 11-T-0500

| | | | | |
|---------|--------------------|------------------|-------------------|-----------------|
| REV.: D | ECN NO.: 17-T-0107 | DRAWN: Kunwarani | CHK'D.: Vasanthan | DATE: 03-Apr-17 |
|---------|--------------------|------------------|-------------------|-----------------|

"PROPRIETARY DATA" IS INCLUDED IN THE INFORMATION DISCLOSED HEREIN AND IS THE SOLE PROPERTY OF BS&B PRESSURE SAFETY MANAGEMENT, L.L.C. THIS INFORMATION IS SUBMITTED IN CONFIDENCE AND NEITHER THIS DOCUMENT NOR THE INFORMATION DISCLOSED HEREIN SHALL BE REPRODUCED OR TRANSFERRED TO OTHER DOCUMENTS OR DISCLOSED TO OTHERS FOR MANUFACTURING OR FOR ANY OTHER PURPOSE EXCEPT AS SPECIFICALLY AUTHORIZED IN WRITING BY BS&B PRESSURE SAFETY MANAGEMENT, L.L.C. US AND INTERNATIONAL PATENTS PENDING.

Check the installation conditions for the BPIV Valve

1. Ensure that the flow path orientation of the installation matches that for which the BPIV was calibrated.
2. Ensure that the BPIV rotating disc is protected within the BPIV body in the fully closed position.
3. Ensure that the BPIV rotating disc cannot contact upstream or downstream components when in the fully open position.

BS&B SUPERVISORY SERVICES

1. BS&B recommends that its supervisory services are employed during BPIV Installation.



BS&B SAFETY SYSTEMS, L.L.C.

SPECIAL ENGINEERING INSTRUCTIONS

DRAWN BY Kunwarane NO. II-MR-0031
 CHK'D. BY SIRISH DATE 9-22-11 SHEET 11 OF 32
 APP. BY Chank Beau REVISION 0 RELEASE NO. 11-T-0500

| | | | | |
|---------|--------------------|------------------|-------------------|-----------------|
| REV.: D | ECN NO.: 17-T-0107 | DRAWN: Kunwarane | CHK'D.: Vasanthan | DATE: 03-Apr-17 |
|---------|--------------------|------------------|-------------------|-----------------|

“PROPRIETARY DATA” IS INCLUDED IN THE INFORMATION DISCLOSED HEREIN AND IS THE SOLE PROPERTY OF BS&B PRESSURE SAFETY MANAGEMENT, L.L.C. THIS INFORMATION IS SUBMITTED IN CONFIDENCE AND NEITHER THIS DOCUMENT NOR THE INFORMATION DISCLOSED HEREIN SHALL BE REPRODUCED OR TRANSFERRED TO OTHER DOCUMENTS OR DISCLOSED TO OTHERS FOR MANUFACTURING OR FOR ANY OTHER PURPOSE EXCEPT AS SPECIFICALLY AUTHORIZED IN WRITING BY BS&B PRESSURE SAFETY MANAGEMENT, L.L.C. US AND INTERNATIONAL PATENTS PENDING.

BPIV INSTALLATION IN COMPANION FLANGES

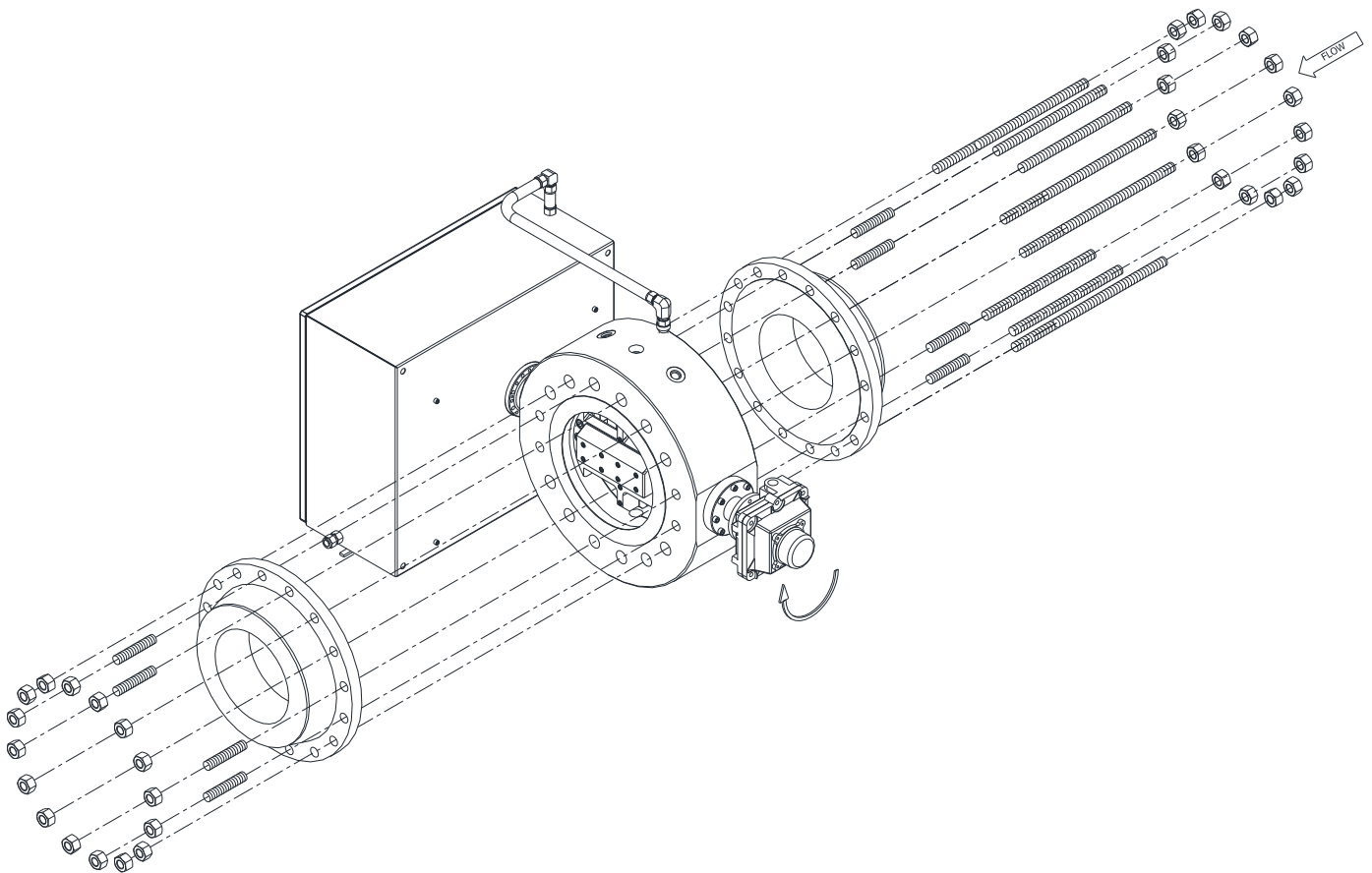

Figure 5. Typical Installation of BPIV with companion flanges
 “Flow Arrow” will be stamped on the Name Tag attached to the side of Valve Body

NOTE: Figure 5 illustrates a “Horizontal Flow Path with Bottom up opening orientation



SPECIAL ENGINEERING INSTRUCTIONS

DRAWN BY Kunwarani NO. II-MR-0031
 CHK'D. BY SIRISH DATE 9-22-11 SHEET 12 OF 32
 APP. BY Chand Beain REVISION 0 RELEASE NO. 11-T-0500

| | | | | | | | | | |
|-------|---|----------|-----------|--------|-----------|---------|-------------|-------|-----------|
| REV.: | D | ECN NO.: | 17-T-0107 | DRAWN: | Kunwarani | CHK'D.: | Chand Beain | DATE: | 03-Apr-17 |
|-------|---|----------|-----------|--------|-----------|---------|-------------|-------|-----------|

"PROPRIETARY DATA" IS INCLUDED IN THE INFORMATION DISCLOSED HEREIN AND IS THE SOLE PROPERTY OF BS&B PRESSURE SAFETY MANAGEMENT, L.L.C. THIS INFORMATION IS SUBMITTED IN CONFIDENCE AND NEITHER THIS DOCUMENT NOR THE INFORMATION DISCLOSED HEREIN SHALL BE REPRODUCED OR TRANSFERRED TO OTHER DOCUMENTS OR DISCLOSED TO OTHERS FOR MANUFACTURING OR FOR ANY OTHER PURPOSE EXCEPT AS SPECIFICALLY AUTHORIZED IN WRITING BY BS&B PRESSURE SAFETY MANAGEMENT, L.L.C. US AND INTERNATIONAL PATENTS PENDING.

BPIV Installation Procedure Between Companion Flanges

1. Place the BPIV valve body in between companion flanges as shown in Figure 5. Make certain that the flow arrow on the body and the orientation arrow in the mechanism are correctly orientated as shown in Figure 5.
2. Install the companion flange gaskets. Ensure gaskets that meet the required BS&B installation torque values shown in Table 1 for compressed fiber, for Flexitallic® "Type LS" or Flexitallic® "Type CGI" are used. Other gasket types or those that require different companion flange stud torque values must be approved by BS&B before use.
3. Install the studs with nuts. Tighten all nuts finger-tight before applying torque. Even torque can be achieved by applying the torque in 1/4 increments of the desired final torque. The torque shall be applied in a criss-cross pattern. Evenly torque the studs to the value listed in Table 1, using a calibrated torque wrench.

TABLE 1: BPIV VALVE COMPANION FLANGE TORQUE

| Valve Size | | Flange Rating | | Number of Studs | Diam. Of Studs | Flexitallic® CGI Stud Torque (Flanged Seal Retainer Rings ONLY) | | Flexitallic® "LS" Stud Torque | | Compressed Fiber Stud Torque | |
|------------|-----|---------------|--------|-----------------|----------------|---|-------|-------------------------------|-----|------------------------------|-------|
| | | | | | | ft-lbs | N-m | ft-lbs | N-m | ft-lbs | N-m |
| in | mm | ANSI | Series | | in | ft-lbs | N-m | ft-lbs | N-m | ft-lbs | N-m |
| 2 | 50 | 150 | - | 4 | .625 | 90 | 122 | 50 | 68 | 51 | 69 |
| | | 300 | | 8 | .625 | 90 | 122 | 50 | 68 | 52 | 70 |
| | | 600 | | 8 | .625 | 90 | 122 | 50 | 68 | 76 | 103 |
| | | 900 | | 8 | .875 | 240 | 325 | 133 | 180 | 248 | 336 |
| 3 | 125 | 150 | - | 4 | .625 | 90 | 122 | 50 | 68 | 60 | 82 |
| | | 300 | | 8 | .75 | 150 | 203 | 83 | 112 | 95 | 129 |
| | | 600 | | 8 | .75 | 150 | 203 | 83 | 112 | 142 | 192 |
| | | 900 | | 8 | .875 | 240 | 325 | 133 | 180 | 305 | 414 |
| 4 | 100 | 150 | - | 8 | .625 | 90 | 122 | 50 | 68 | 51 | 70 |
| | | 300 | | 8 | .75 | 150 | 203 | 83 | 112 | 112 | 152 |
| | | 600 | | 8 | .875 | 240 | 325 | 133 | 180 | 249 | 338 |
| | | 900 | | 8 | 1.125 | 533 | 722 | 296 | 400 | 561 | 761 |
| 6 | 150 | 150 | - | 8 | .75 | 150 | 203 | 83 | 112 | 85 | 115 |
| | | 300 | | 12 | .75 | 150 | 203 | 83 | 112 | 120 | 162 |
| | | 600 | | 12 | 1 | 368 | 498 | 204 | 276 | 335 | 454 |
| | | 900 | | 12 | 1.125 | 533 | 722 | 296 | 400 | 589 | 798 |
| 8 | 200 | 150 | - | 8 | .75 | 150 | 203 | 83 | 112 | 97 | 132 |
| | | 300 | | 12 | .875 | 240 | 325 | 133 | 180 | 191 | 259 |
| | | 600 | | 12 | 1.125 | 533 | 722 | 296 | 400 | 494 | 670 |
| | | 900 | | 12 | 1.375 | 1,020 | 1,383 | 567 | 769 | 1,054 | 1,429 |
| 10 | 250 | 150 | - | 12 | .875 | 240 | 325 | 133 | 180 | 127 | 173 |
| | | 300 | | 16 | 1 | 368 | 498 | 204 | 276 | 240 | 325 |
| | | 600 | | 16 | 1.25 | 750 | 1,017 | 417 | 565 | 630 | 854 |



BS&B SAFETY SYSTEMS, L.L.C.

SPECIAL ENGINEERING INSTRUCTIONS

DRAWN BY Kunwarani NO. II-MR-0031
 CHK'D. BY SIRISH DATE 9-22-11 SHEET 13 OF 32
 APP. BY Chand Beain REVISION 0 RELEASE NO. 11-T-0500

| | | | | | | | | | |
|-------|---|----------|-----------|--------|-----------|---------|-----------|-------|-----------|
| REV.: | D | ECN NO.: | 17-T-0107 | DRAWN: | Kunwarani | CHK'D.: | Vasudevan | DATE: | 03-Apr-17 |
|-------|---|----------|-----------|--------|-----------|---------|-----------|-------|-----------|

“PROPRIETARY DATA” IS INCLUDED IN THE INFORMATION DISCLOSED HEREIN AND IS THE SOLE PROPERTY OF BS&B PRESSURE SAFETY MANAGEMENT, L.L.C. THIS INFORMATION IS SUBMITTED IN CONFIDENCE AND NEITHER THIS DOCUMENT NOR THE INFORMATION DISCLOSED HEREIN SHALL BE REPRODUCED OR TRANSFERRED TO OTHER DOCUMENTS OR DISCLOSED TO OTHERS FOR MANUFACTURING OR FOR ANY OTHER PURPOSE EXCEPT AS SPECIFICALLY AUTHORIZED IN WRITING BY BS&B PRESSURE SAFETY MANAGEMENT, L.L.C. US AND INTERNATIONAL PATENTS PENDING.

| Valve Size | | Flange Rating | | Number of Studs | Diam. Of Studs | Flexitallic® CGI Stud Torque (Flanged Seal Retainer Rings ONLY) | | Flexitallic® “LS” Stud Torque | | Compressed Fiber Stud Torque | |
|------------|-----|---------------|--------|-----------------|----------------|---|--------|-------------------------------|-------|------------------------------|-------|
| | | | | | | ft-lbs | N-m | ft-lbs | N-m | ft-lbs | N-m |
| in | mm | ANSI | Series | | in | ft-lbs | N-m | ft-lbs | N-m | ft-lbs | N-m |
| | | 900 | | 16 | 1.375 | 1,020 | 1,383 | 567 | 769 | 1,105 | 1,498 |
| 12 | 300 | 150 | - | 12 | .875 | 240 | 325 | 133 | 180 | 145 | 197 |
| | | 300 | | 16 | 1.125 | 533 | 722 | 296 | 400 | 351 | 475 |
| | | 600 | | 20 | 1.25 | 750 | 1,017 | 417 | 565 | 623 | 845 |
| | | 900 | | 20 | 1.375 | 1,020 | 1,383 | 567 | 769 | 1,179 | 1,598 |
| 14 | 350 | 150 | - | 12 | 1 | 368 | 498 | 204 | 276 | 206 | 280 |
| | | 300 | | 20 | 1.125 | 533 | 722 | 296 | 400 | 361 | 490 |
| | | 600 | | 20 | 1.375 | 1,020 | 1,383 | 567 | 769 | 801 | 1,086 |
| | | 900 | | 20 | 1.5 | 1,200 | 1,627 | 540 | 732 | 1,550 | 2,102 |
| 16 | 400 | 150 | - | 16 | 1 | 368 | 498 | 204 | 276 | 200 | 272 |
| | | 300 | | 20 | 1.25 | 750 | 1,017 | 417 | 565 | 486 | 659 |
| | | 600 | | 20 | 1.5 | 1,200 | 1,627 | 540 | 732 | 1,095 | 1,484 |
| | | 900 | | 20 | 1.625 | 1,650 | 2,237 | 733 | 994 | 1,993 | 2,702 |
| 18 | 450 | 150 | - | 16 | 1.125 | 533 | 722 | 296 | 400 | 273 | 370 |
| | | 300 | | 24 | 1.25 | 750 | 1,017 | 417 | 565 | 481 | 652 |
| | | 600 | | 20 | 1.625 | 1,650 | 2,237 | 733 | 994 | 1,367 | 1,853 |
| | | 900 | | 20 | 1.875 | 3,000 | 4,067 | 1,333 | 1,807 | 2,813 | 3,814 |
| 20 | 500 | 150 | - | 20 | 1.125 | 533 | 722 | 296 | 400 | 268 | 363 |
| | | 300 | | 24 | 1.25 | 750 | 1,017 | 417 | 565 | 519 | 704 |
| | | 600 | | 24 | 1.625 | 1,650 | 2,237 | 733 | 994 | 1,374 | 1,862 |
| | | 900 | | 20 | 2 | 3,300 | 4,474 | 1,467 | 1,989 | 3,370 | 4,568 |
| 24 | 600 | 150 | - | 20 | 1.25 | 750 | 1,017 | 417 | 565 | 379 | 514 |
| | | 300 | | 24 | 1.5 | 1,200 | 1,627 | 540 | 732 | 883 | 1,197 |
| | | 600 | | 24 | 1.875 | 3,000 | 4,067 | 1,333 | 1,807 | 2,070 | 2,806 |
| | | 900 | | 20 | 2.5 | 6,600 | 8,948 | 2,933 | 3,977 | 6,080 | 8,244 |
| 26 | 650 | 150 | A | 24 | 1.25 | 750 | 1,017 | 417 | 565 | 373 | 506 |
| | | | B | 36 | .75 | 150 | 203 | 83 | 112 | 91 | 123 |
| | | 300 | A | 28 | 1.625 | 1,650 | 2,237 | 733 | 994 | 1,038 | 1,407 |
| | | | B | 32 | 1.25 | 750 | 1,017 | 417 | 565 | 495 | 671 |
| | | 600 | A | 28 | 1.875 | 3,000 | 4,067 | 1,333 | 1,807 | 2,091 | 2,835 |
| | | | B | 28 | 1.625 | 1,650 | 2,237 | 733 | 994 | 1,279 | 1,734 |
| | | 900 | A | 20 | 2.75 | 8,880 | 12,040 | 3,947 | 5,351 | 6,846 | 9,281 |
| | | | B | 20 | 2.5 | 6,600 | 8,948 | 2,933 | 3,977 | 5,294 | 7,178 |
| 28 | 700 | 150 | A | 28 | 1.25 | 750 | 1,017 | 417 | 565 | 369 | 500 |
| | | | B | 40 | .75 | 150 | 203 | 83 | 112 | 91 | 123 |
| | | 300 | A | 28 | 1.625 | 1,650 | 2,237 | 733 | 994 | 1,082 | 1,467 |
| | | | B | 36 | 1.25 | 750 | 1,017 | 417 | 565 | 494 | 669 |
| | | 600 | A | 28 | 2 | 3,300 | 4,474 | 1,467 | 1,989 | 2,477 | 3,359 |



BS&B SAFETY SYSTEMS, L.L.C.

SPECIAL ENGINEERING INSTRUCTIONS

DRAWN BY Kunwarani NO. II-MR-0031
 CHK'D. BY SIRISH DATE 9-22-11 SHEET 14 OF 32
 APP. BY Chand Beain REVISION 0 RELEASE NO. 11-T-0500

| | | | | | | | | | |
|-------|---|----------|-----------|--------|-----------|---------|-------------|-------|-----------|
| REV.: | D | ECN NO.: | 17-T-0107 | DRAWN: | Kunwarani | CHK'D.: | Chand Beain | DATE: | 03-Apr-17 |
|-------|---|----------|-----------|--------|-----------|---------|-------------|-------|-----------|

"PROPRIETARY DATA" IS INCLUDED IN THE INFORMATION DISCLOSED HEREIN AND IS THE SOLE PROPERTY OF BS&B PRESSURE SAFETY MANAGEMENT, L.L.C. THIS INFORMATION IS SUBMITTED IN CONFIDENCE AND NEITHER THIS DOCUMENT NOR THE INFORMATION DISCLOSED HEREIN SHALL BE REPRODUCED OR TRANSFERRED TO OTHER DOCUMENTS OR DISCLOSED TO OTHERS FOR MANUFACTURING OR FOR ANY OTHER PURPOSE EXCEPT AS SPECIFICALLY AUTHORIZED IN WRITING BY BS&B PRESSURE SAFETY MANAGEMENT, L.L.C. US AND INTERNATIONAL PATENTS PENDING.

| Valve Size | | Flange Rating | | Number of Studs | Diam. Of Studs | Flexitallic® CGI Stud Torque (Flanged Seal Retainer Rings ONLY) | | Flexitallic® "LS" Stud Torque | | Compressed Fiber Stud Torque | |
|------------|-----|---------------|--------|-----------------|----------------|---|--------|-------------------------------|--------|------------------------------|--------|
| in | mm | ANSI | Series | | | in | ft-lbs | N-m | ft-lbs | N-m | ft-lbs |
| | | 900 | B | 28 | 1.75 | 2,250 | 3,051 | 1,000 | 1,356 | 1,604 | 2,175 |
| | | | A | 20 | 3 | 11,580 | 15,700 | 5,147 | 6,978 | 8,668 | 11,753 |
| | | | B | 20 | 2.75 | 8,880 | 12,040 | 3,947 | 5,351 | 6,837 | 9,270 |
| 30 | 750 | 150 | A | 28 | 1.25 | 750 | 1,017 | 417 | 565 | 381 | 517 |
| | | | B | 44 | .75 | 150 | 203 | 83 | 112 | 91 | 124 |
| | | 300 | A | 28 | 1.75 | 2,250 | 3,051 | 1,000 | 1,356 | 1,354 | 1,836 |
| | | | B | 36 | 1.375 | 1,020 | 1,383 | 567 | 769 | 645 | 875 |
| | | 600 | A | 28 | 2 | 3,300 | 4,474 | 1,467 | 1,989 | 2,626 | 3,561 |
| | | | B | 28 | 1.875 | 3,000 | 4,067 | 1,333 | 1,807 | 1,976 | 2,679 |
| | | 900 | A | 20 | 3 | 11,580 | 15,700 | 5,147 | 6,978 | 9,229 | 12,512 |
| | | | B | 20 | 3 | 11,580 | 15,700 | 5,147 | 6,978 | 8,580 | 11,633 |
| 32 | 800 | 150 | A | 28 | 1.5 | 1,200 | 1,627 | 540 | 732 | 626 | 849 |
| | | | B | 48 | .75 | 150 | 203 | 83 | 112 | 93 | 125 |
| | | 300 | A | 28 | 1.875 | 3,000 | 4,067 | 1,333 | 1,807 | 1,641 | 2,225 |
| | | | B | 32 | 1.5 | 1,200 | 1,627 | 540 | 732 | 865 | 1,173 |
| | | 600 | A | 28 | 2.25 | 4,770 | 6,467 | 2,120 | 2,874 | 3,453 | 4,682 |
| | | | B | 28 | 2 | 3,300 | 4,474 | 1,467 | 1,989 | 2,374 | 3,219 |
| | | 900 | A | 20 | 3.25 | 15,000 | 20,337 | 6,667 | 9,039 | 11,420 | 15,483 |
| | | | B | 20 | 3 | 11,580 | 15,700 | 5,147 | 6,978 | 9,054 | 12,276 |
| 34 | 850 | 150 | A | 32 | 1.5 | 1,200 | 1,627 | 540 | 732 | 617 | 837 |
| | | | B | 40 | .875 | 240 | 325 | 133 | 180 | 147 | 199 |
| | | 300 | A | 28 | 1.875 | 3,000 | 4,067 | 1,333 | 1,807 | 1,699 | 2,303 |
| | | | B | 36 | 1.5 | 1,200 | 1,627 | 540 | 732 | 856 | 1,160 |
| | | 600 | A | 28 | 2.25 | 4,770 | 6,467 | 2,120 | 2,874 | 3,601 | 4,882 |
| | | | B | 24 | 2.25 | 4,770 | 6,467 | 2,120 | 2,874 | 3,495 | 4,739 |
| | | 900 | A | 20 | 3.5 | 18,750 | 25,422 | 8,333 | 11,299 | 13,943 | 18,904 |
| | | | B | 20 | 3.25 | 15,000 | 20,337 | 6,667 | 9,039 | 11,129 | 15,090 |
| 36 | 900 | 150 | A | 32 | 1.5 | 1,200 | 1,627 | 540 | 732 | 636 | 862 |
| | | | B | 44 | .875 | 240 | 325 | 133 | 180 | 147 | 199 |
| | | 300 | A | 32 | 2 | 3,300 | 4,474 | 1,467 | 1,989 | 1,930 | 2,616 |
| | | | B | 32 | 1.625 | 1,650 | 2,237 | 733 | 994 | 1,104 | 1,497 |
| | | 600 | A | 28 | 2.5 | 6,600 | 8,948 | 2,933 | 3,977 | 4,660 | 6,318 |
| | | | B | 28 | 2.25 | 4,770 | 6,467 | 2,120 | 2,874 | 3,364 | 4,561 |
| | | 900 | A | 20 | 3.5 | 18,750 | 25,422 | 8,333 | 11,299 | 14,697 | 19,926 |
| | | | B | 24 | 3 | 11,580 | 15,700 | 5,147 | 6,978 | 8,971 | 12,164 |
| 38 | 950 | 150 | A | 32 | 1.5 | 1,200 | 1,627 | 540 | 732 | 659 | 894 |
| | | | B | 40 | 1 | 368 | 498 | 204 | 276 | 213 | 289 |
| | | 300 | A | 32 | 1.5 | 1,200 | 1,627 | 540 | 732 | 921 | 1,249 |



SPECIAL ENGINEERING INSTRUCTIONS

DRAWN BY Kunwarani NO. II-MR-0031
 CHK'D. BY SIRISH DATE 9-22-11 SHEET 15 OF 32
 APP. BY Chuk Beau REVISION 0 RELEASE NO. 11-T-0500

| | | | | | | | | | |
|-------|---|----------|-----------|--------|-----------|---------|-----------|-------|-----------|
| REV.: | D | ECN NO.: | 17-T-0107 | DRAWN: | Kunwarani | CHK'D.: | Chuk Beau | DATE: | 03-Apr-17 |
|-------|---|----------|-----------|--------|-----------|---------|-----------|-------|-----------|

"PROPRIETARY DATA" IS INCLUDED IN THE INFORMATION DISCLOSED HEREIN AND IS THE SOLE PROPERTY OF BS&B PRESSURE SAFETY MANAGEMENT, L.L.C. THIS INFORMATION IS SUBMITTED IN CONFIDENCE AND NEITHER THIS DOCUMENT NOR THE INFORMATION DISCLOSED HEREIN SHALL BE REPRODUCED OR TRANSFERRED TO OTHER DOCUMENTS OR DISCLOSED TO OTHERS FOR MANUFACTURING OR FOR ANY OTHER PURPOSE EXCEPT AS SPECIFICALLY AUTHORIZED IN WRITING BY BS&B PRESSURE SAFETY MANAGEMENT, L.L.C. US AND INTERNATIONAL PATENTS PENDING.

| Valve Size | | Flange Rating | | Number of Studs | Diam. Of Studs | Flexitallic® CGI Stud Torque (Flanged Seal Retainer Rings ONLY) | | Flexitallic® "LS" Stud Torque | | Compressed Fiber Stud Torque | |
|------------|------|---------------|--------|-----------------|----------------|---|--------|-------------------------------|--------|------------------------------|--------|
| in | mm | ANSI | Series | | | in | ft-lbs | N-m | ft-lbs | N-m | ft-lbs |
| | | | B | 36 | 1.625 | 1,650 | 2,237 | 733 | 994 | 1,103 | 1,495 |
| | | 600 | A | 28 | 2.25 | 4,770 | 6,467 | 2,120 | 2,874 | 3,538 | 4,797 |
| | | 900 | A | 20 | 3.5 | 18,750 | 25,422 | 8,333 | 11,299 | 14,363 | 19,474 |
| 40 | 1000 | 150 | A | 36 | 1.5 | 1,200 | 1,627 | 540 | 732 | 614 | 833 |
| | | | B | 44 | 1 | 368 | 498 | 204 | 276 | 212 | 287 |
| | | 300 | A | 32 | 1.625 | 1,650 | 2,237 | 733 | 994 | 1,152 | 1,562 |
| | | | B | 40 | 1.625 | 1,650 | 2,237 | 733 | 994 | 1,085 | 1,471 |
| | | 600 | A | 32 | 2.25 | 4,770 | 6,467 | 2,120 | 2,874 | 3,426 | 4,644 |
| | | 900 | A | 24 | 3.5 | 18,750 | 25,422 | 8,333 | 11,299 | 13,487 | 18,287 |
| 42 | 1050 | 150 | A | 36 | 1.5 | 1,200 | 1,627 | 540 | 732 | 633 | 858 |
| | | | B | 48 | 1 | 368 | 498 | 204 | 276 | 211 | 286 |
| | | 300 | A | 32 | 1.625 | 1,650 | 2,237 | 733 | 994 | 1,196 | 1,621 |
| | | | B | 36 | 1.75 | 2,250 | 3,051 | 1,000 | 1,356 | 1,385 | 1,878 |
| | | 600 | A | 28 | 2.5 | 6,600 | 8,948 | 2,933 | 3,977 | 4,796 | 6,502 |
| | | 900 | A | 24 | 3.5 | 18,750 | 25,422 | 8,333 | 11,299 | 13,956 | 18,922 |
| 44 | 1100 | 150 | A | 40 | 1.5 | 1,200 | 1,627 | 540 | 732 | 628 | 851 |
| | | | B | 52 | 1 | 368 | 498 | 204 | 276 | 210 | 285 |
| | | 300 | A | 32 | 1.75 | 2,250 | 3,051 | 1,000 | 1,356 | 1,454 | 1,971 |
| | | | B | 40 | 1.75 | 2,250 | 3,051 | 1,000 | 1,356 | 1,361 | 1,846 |
| | | 600 | A | 32 | 2.5 | 6,600 | 8,948 | 2,933 | 3,977 | 4,632 | 6,280 |
| | | 900 | A | 24 | 3.75 | 23,100 | 31,319 | 10,267 | 13,920 | 16,801 | 22,779 |
| 46 | 1150 | 150 | A | 40 | 1.5 | 1,200 | 1,627 | 540 | 732 | 643 | 872 |
| | | | B | 40 | 1.125 | 533 | 722 | 296 | 400 | 323 | 438 |
| | | 300 | A | 28 | 1.875 | 3,000 | 4,067 | 1,333 | 1,807 | 1,870 | 2,535 |
| | | | B | 36 | 1.875 | 3,000 | 4,067 | 1,333 | 1,807 | 1,747 | 2,369 |
| | | 600 | A | 32 | 2.5 | 6,600 | 8,948 | 2,933 | 3,977 | 4,832 | 6,552 |
| | | 900 | A | 24 | 4 | 28,136 | 38,148 | 12,505 | 16,955 | 20,024 | 27,148 |
| 48 | 1200 | 150 | A | 44 | 1.5 | 1,200 | 1,627 | 540 | 732 | 638 | 865 |
| | | | B | 44 | 1.125 | 533 | 722 | 296 | 400 | 319 | 433 |
| | | 300 | A | 32 | 1.875 | 3,000 | 4,067 | 1,333 | 1,807 | 1,807 | 2,450 |
| | | | B | 40 | 1.875 | 3,000 | 4,067 | 1,333 | 1,807 | 1,711 | 2,319 |
| | | 600 | A | 32 | 2.75 | 8,880 | 12,040 | 3,947 | 5,351 | 6,143 | 8,329 |
| | | 900 | A | 24 | 4 | 28,136 | 38,148 | 12,505 | 16,955 | 20,625 | 27,964 |
| 50 | 1250 | 150 | A | 44 | 1.75 | 2,250 | 3,051 | 1,000 | 1,356 | 1,012 | 1,373 |
| | | | B | 48 | 1.125 | 533 | 722 | 296 | 400 | 316 | 428 |
| | | 300 | A | 32 | 2 | 3,300 | 4,474 | 1,467 | 1,989 | 2,145 | 2,908 |
| | | | B | 44 | 1.875 | 3,000 | 4,067 | 1,333 | 1,807 | 1,683 | 2,282 |
| | | 600 | A | 28 | 3 | 11,580 | 15,700 | 5,147 | 6,978 | 8,149 | 11,048 |



SPECIAL ENGINEERING INSTRUCTIONS

DRAWN BY Kunwaranel NO. II-MR-0031
 CHK'D. BY SIRISH DATE 9-22-11 SHEET 16 OF 32
 APP. BY Chank Beau REVISION 0 RELEASE NO. 11-T-0500

| | | | | |
|---------|--------------------|-------------------|----------------------|-----------------|
| REV.: D | ECN NO.: 17-T-0107 | DRAWN: Kunwaranel | CHK'D.: Vasekthousak | DATE: 03-Apr-17 |
|---------|--------------------|-------------------|----------------------|-----------------|

"PROPRIETARY DATA" IS INCLUDED IN THE INFORMATION DISCLOSED HEREIN AND IS THE SOLE PROPERTY OF BS&B PRESSURE SAFETY MANAGEMENT, L.L.C. THIS INFORMATION IS SUBMITTED IN CONFIDENCE AND NEITHER THIS DOCUMENT NOR THE INFORMATION DISCLOSED HEREIN SHALL BE REPRODUCED OR TRANSFERRED TO OTHER DOCUMENTS OR DISCLOSED TO OTHERS FOR MANUFACTURING OR FOR ANY OTHER PURPOSE EXCEPT AS SPECIFICALLY AUTHORIZED IN WRITING BY BS&B PRESSURE SAFETY MANAGEMENT, L.L.C. US AND INTERNATIONAL PATENTS PENDING.

| Valve Size | | Flange Rating | | Number of Studs | Diam. Of Studs | Flexitallic® CGI Stud Torque (Flanged Seal Retainer Rings ONLY) | | Flexitallic® "LS" Stud Torque | | Compressed Fiber Stud Torque | |
|------------|------|---------------|--------|-----------------|----------------|---|--------|-------------------------------|--------|------------------------------|--------|
| in | mm | ANSI | Series | | | in | ft-lbs | N-m | ft-lbs | N-m | ft-lbs |
| 52 | 1300 | 150 | A | 44 | 1.75 | 2,250 | 3,051 | 1,000 | 1,356 | 1,034 | 1,402 |
| | | | B | 52 | 1.125 | 533 | 722 | 296 | 400 | 313 | 425 |
| | | 300 | A | 32 | 2 | 3,300 | 4,474 | 1,467 | 1,989 | 2,211 | 2,998 |
| | | | B | 48 | 1.875 | 3,000 | 4,067 | 1,333 | 1,807 | 1,662 | 2,253 |
| | | 600 | A | 32 | 3 | 11,580 | 15,700 | 5,147 | 6,978 | 7,842 | 10,632 |
| 54 | 1350 | 150 | A | 44 | 1.75 | 2,250 | 3,051 | 1,000 | 1,356 | 1,056 | 1,431 |
| | | | B | 56 | 1.125 | 533 | 722 | 296 | 400 | 313 | 425 |
| | | 300 | A | 28 | 2.25 | 4,770 | 6,467 | 2,120 | 2,874 | 3,159 | 4,283 |
| | | | B | 48 | 1.875 | 3,000 | 4,067 | 1,333 | 1,807 | 1,767 | 2,396 |
| | | 600 | A | 32 | 3 | 11,580 | 15,700 | 5,147 | 6,978 | 8,114 | 11,002 |
| 56 | 1400 | 150 | A | 48 | 1.75 | 2,250 | 3,051 | 1,000 | 1,356 | 1,050 | 1,423 |
| | | | B | 60 | 1.125 | 533 | 722 | 296 | 400 | 312 | 423 |
| | | 300 | A | 28 | 2.25 | 4,770 | 6,467 | 2,120 | 2,874 | 3,253 | 4,411 |
| | | | B | 36 | 2.25 | 4,770 | 6,467 | 2,120 | 2,874 | 3,034 | 4,113 |
| | | 600 | A | 32 | 3.25 | 15,000 | 20,337 | 6,667 | 9,039 | 9,887 | 13,406 |
| 58 | 1450 | 150 | A | 48 | 1.75 | 2,250 | 3,051 | 1,000 | 1,356 | 1,071 | 1,452 |
| | | | B | 48 | 1.25 | 750 | 1,017 | 417 | 565 | 452 | 612 |
| | | 300 | A | 32 | 2.25 | 4,770 | 6,467 | 2,120 | 2,874 | 3,130 | 4,244 |
| | | | B | 40 | 2.25 | 4,770 | 6,467 | 2,120 | 2,874 | 3,034 | 4,113 |
| | | 600 | A | 32 | 3.25 | 15,000 | 20,337 | 6,667 | 9,039 | 10,146 | 13,756 |
| 60 | 1500 | 150 | A | 52 | 1.75 | 2,250 | 3,051 | 1,000 | 1,356 | 1,061 | 1,439 |
| | | | B | 52 | 1.25 | 750 | 1,017 | 417 | 565 | 446 | 605 |
| | | 300 | A | 32 | 2.25 | 4,770 | 6,467 | 2,120 | 2,874 | 3,215 | 4,359 |
| | | | B | 40 | 2.25 | 4,770 | 6,467 | 2,120 | 2,874 | 3,057 | 4,145 |
| | | 600 | A | 28 | 3.5 | 18,750 | 25,422 | 8,333 | 11,299 | 13,024 | 17,658 |

NOTES: Torque values are based on the use of gaskets shown. Consult BS&B Pressure Safety Management, L.L.C. for flanges in other materials when suppliers recommend torque values higher than the BS&B Pressure Safety Management, L.L.C. recommended torque values and if gasket type differs from BS&B Pressure Safety Management, L.L.C. recommendation.

2" to 24" valve sizes are derived from ASME B16.5. Sizes 26" and above are derived from ASME B16.47.

Recommended CGI stud torques are based on a design stress of 45,000 psi. These torque values to be used with the flanged retainer ring design only. If the applied torques are to exceed 50,000 psi stud stress, contact BS&B Pressure Safety Management, L.L.C. for engineering verification.

Recommended LS stud torques are based on a design stress of 20,000 psi to 25,000 psi.

Recommended compressed fiber stud torques are derived from Klingsil® recommended gasket values for the ASME Section VIII Div 1, Mandatory Appendix 2 calculation.



BS&B SAFETY SYSTEMS, L.L.C.

SPECIAL ENGINEERING INSTRUCTIONS

DRAWN BY Kunwarani NO. II-MR-0031
 CHK'D. BY SIRISH DATE 9-22-11 SHEET 17 OF 32
 APP. BY Chuck Beair REVISION 0 RELEASE NO. 11-T-0500

| | | | | |
|---------|--------------------|------------------|-------------------|-----------------|
| REV.: D | ECN NO.: 17-T-0107 | DRAWN: Kunwarani | CHK'D.: Vasudevan | DATE: 03-Apr-17 |
|---------|--------------------|------------------|-------------------|-----------------|

"PROPRIETARY DATA" IS INCLUDED IN THE INFORMATION DISCLOSED HEREIN AND IS THE SOLE PROPERTY OF BS&B PRESSURE SAFETY MANAGEMENT, L.L.C. THIS INFORMATION IS SUBMITTED IN CONFIDENCE AND NEITHER THIS DOCUMENT NOR THE INFORMATION DISCLOSED HEREIN SHALL BE REPRODUCED OR TRANSFERRED TO OTHER DOCUMENTS OR DISCLOSED TO OTHERS FOR MANUFACTURING OR FOR ANY OTHER PURPOSE EXCEPT AS SPECIFICALLY AUTHORIZED IN WRITING BY BS&B PRESSURE SAFETY MANAGEMENT, L.L.C. US AND INTERNATIONAL PATENTS PENDING.

OPERATION INSTRUCTIONS

BUCKLING PIN INSTALLATION FOR BPIV M4200 MECHANISM

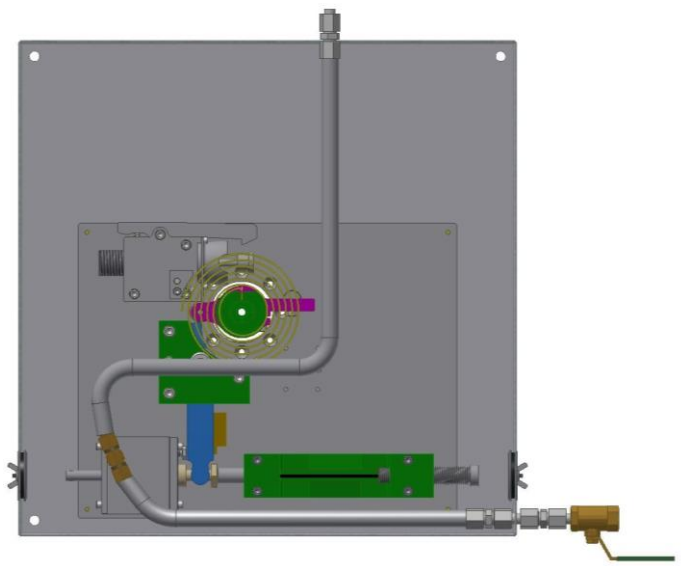

Image – 3: Front view of Mechanism (clock spring)

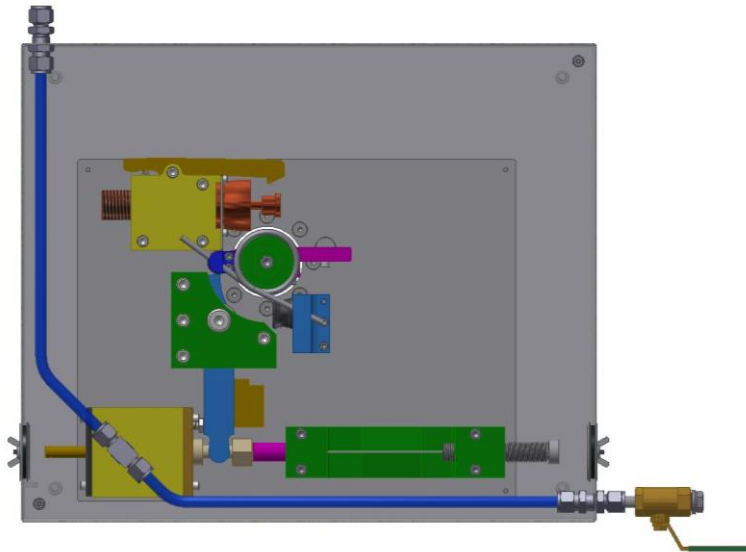

Image – 3(Alternate): Front view of Mechanism (torsion spring)



SPECIAL ENGINEERING INSTRUCTIONS

DRAWN BY Kunwarani NO. II-MR-0031
CHK'D. BY SIRISH DATE 9-22-11 SHEET 18 OF 32
APP. BY Chank Beain REVISION 0 RELEASE NO. 11-T-0500

| | | | | | | | | | |
|-------|---|----------|-----------|--------|-----------|---------|-----------|-------|-----------|
| REV.: | D | ECN NO.: | 17-T-0107 | DRAWN: | Kunwarani | CHK'D.: | Vasanthan | DATE: | 03-Apr-17 |
|-------|---|----------|-----------|--------|-----------|---------|-----------|-------|-----------|

"PROPRIETARY DATA" IS INCLUDED IN THE INFORMATION DISCLOSED HEREIN AND IS THE SOLE PROPERTY OF BS&B PRESSURE SAFETY MANAGEMENT, L.L.C. THIS INFORMATION IS SUBMITTED IN CONFIDENCE AND NEITHER THIS DOCUMENT NOR THE INFORMATION DISCLOSED HEREIN SHALL BE REPRODUCED OR TRANSFERRED TO OTHER DOCUMENTS OR DISCLOSED TO OTHERS FOR MANUFACTURING OR FOR ANY OTHER PURPOSE EXCEPT AS SPECIFICALLY AUTHORIZED IN WRITING BY BS&B PRESSURE SAFETY MANAGEMENT, L.L.C. US AND INTERNATIONAL PATENTS PENDING.

Installation of Buckling Pin into Mechanism after valve has been installed into piping system.

Note: Before you install the Buckling pin in the BPIV the valve shall be at ambient conditions.

Inspect the BPIV Valve Mechanism Assembly

1. Verify that the system pressure is zero at the valve location before attempting any procedures inside the mechanism enclosure.
2. Inspect the mechanism for external and internal damage. Damage to the mechanism could cause the valve to open at a pressure other than the rated pressure.
3. The mechanism assembly should be free of dirt, grime, grit and corrosion. Do not store foreign objects in the mechanism enclosure.
4. The BPIV valve mechanism must not be machined or modified in any way.
5. The BPIV shall be fitted with a "Red Shipping Pin" and "Red Trigger Stop Spacer", appropriately marked (refer image2). **Remove the "Red Shipping Pin" and "Red Trigger Stop Spacer" only after the valve has been correctly installed in the piping system per Pin Installation Instructions. Note: "Red Shipping Pin" and "Red Trigger Stop Spacer" are two (2) pieces that work together to prevent the trigger from kicking out during shipping and handling.**

Inspect the Buckling Pin

1. Inspect the buckling pin. Make sure the new pin have not been bent or damaged. **Do not install a damaged buckling pin. Do not install an untagged buckling pin.**
2. Do not machine or modify the buckling pin in any way. The buckling pins are precision manufactured components. Any alteration voids the warranty on this product.
3. Do not install anything other than the buckling pin that is specifically marked on its tag for use in this valve. Replacement buckling pins can be ordered, by the lot number printed on the pin tag, , from BS&B Pressure Safety Management, L.L.C.

Contact details: Tel: +1 (918) 622-5950; or visit our web site <http://www.bsbsystems.com>



SPECIAL ENGINEERING INSTRUCTIONS

DRAWN BY Kunwarani NO. II-MR-0031
 CHK'D. BY SIRISH DATE 9-22-11 SHEET 19 OF 32
 APP. BY Chank Beain REVISION 0 RELEASE NO. 11-T-0500

| | | | | |
|---------|--------------------|------------------|-------------------|-----------------|
| REV.: D | ECN NO.: 17-T-0107 | DRAWN: Kunwarani | CHK'D.: Vasanthan | DATE: 03-Apr-17 |
|---------|--------------------|------------------|-------------------|-----------------|

"PROPRIETARY DATA" IS INCLUDED IN THE INFORMATION DISCLOSED HEREIN AND IS THE SOLE PROPERTY OF BS&B PRESSURE SAFETY MANAGEMENT, L.L.C. THIS INFORMATION IS SUBMITTED IN CONFIDENCE AND NEITHER THIS DOCUMENT NOR THE INFORMATION DISCLOSED HEREIN SHALL BE REPRODUCED OR TRANSFERRED TO OTHER DOCUMENTS OR DISCLOSED TO OTHERS FOR MANUFACTURING OR FOR ANY OTHER PURPOSE EXCEPT AS SPECIFICALLY AUTHORIZED IN WRITING BY BS&B PRESSURE SAFETY MANAGEMENT, L.L.C. US AND INTERNATIONAL PATENTS PENDING.

BUCKLING PIN INSTALLATION INSTRUCTIONS FOR BPIV M4200 MECHANISM

PART LIST IDENTIFICATION

- 1) INPUT ARM
- 2) LATCH
- 3) STOPPER BLOCK
- 4) TRIGGER SUPPORT BLOCK ASSEMBLY
- 5) PISTON GUIDE ROD
- 6) ACTUATOR ASSEMBLY
- 7) TRIGGER
- 8) PIN GUIDE BLOCK
- 9) BUCKLING PIN
- 10) PURGE LINE TUBING
- 11) PIN HOLDER
- 12) PIN ADJUSTER SCREW
- 13) SPRING
- 14) ADJUSTMENT SCREW
- 15) SPRING HUB
- 16) WHITEY VALVE
- 17) HOLE SEAL FOR PISTON GUIDE ROD

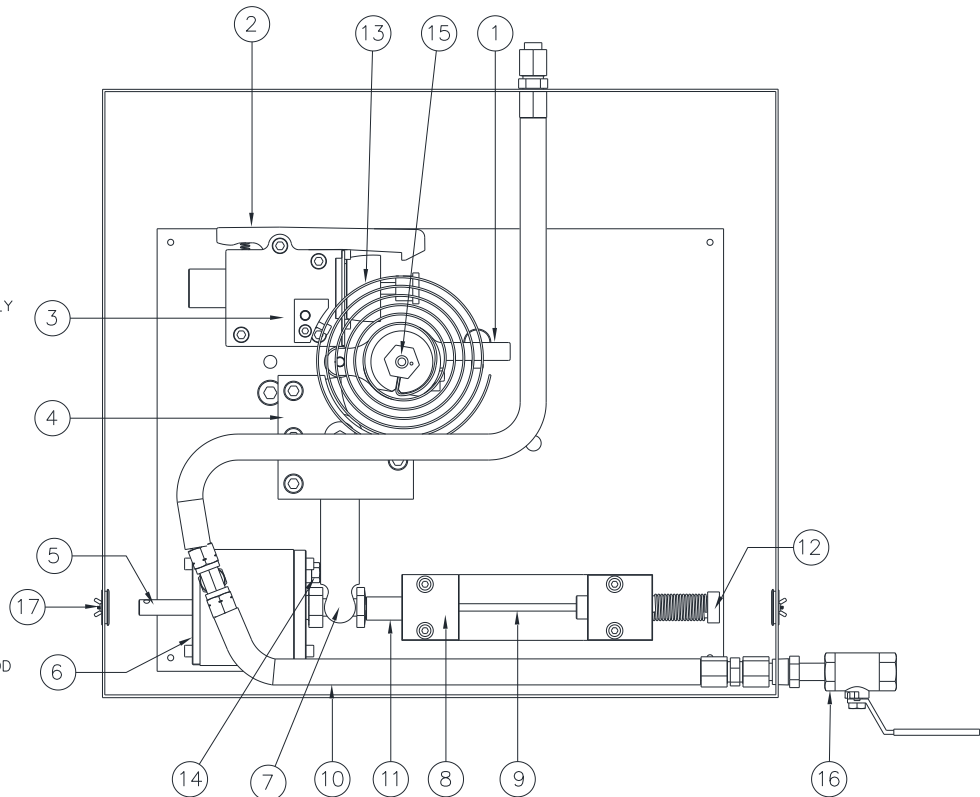

Figure 6. Mechanism Assembly (BPIV Closed) - clock spring

Caution: Do not perform any work inside the mechanism unless the system pressure is verified to be zero, "0psig," upstream and downstream of the valve location and the pilot purge block valve (Whitey valve Item 16) is in the closed position. Failure to do this can cause bodily injury.



SPECIAL ENGINEERING INSTRUCTIONS

DRAWN BY Kunwarani NO. II-MR-0031
 CHK'D. BY SIRISH DATE 9-22-11 SHEET 20 OF 32
 APP. BY Chand Beain REVISION 0 RELEASE NO. 11-T-0500

| | | | | |
|---------|--------------------|------------------|----------------------|-----------------|
| REV.: D | ECN NO.: 17-T-0107 | DRAWN: Kunwarani | CHK'D.: Vasanthkumar | DATE: 03-Apr-17 |
|---------|--------------------|------------------|----------------------|-----------------|

"PROPRIETARY DATA" IS INCLUDED IN THE INFORMATION DISCLOSED HEREIN AND IS THE SOLE PROPERTY OF BS&B PRESSURE SAFETY MANAGEMENT, L.L.C. THIS INFORMATION IS SUBMITTED IN CONFIDENCE AND NEITHER THIS DOCUMENT NOR THE INFORMATION DISCLOSED HEREIN SHALL BE REPRODUCED OR TRANSFERRED TO OTHER DOCUMENTS OR DISCLOSED TO OTHERS FOR MANUFACTURING OR FOR ANY OTHER PURPOSE EXCEPT AS SPECIFICALLY AUTHORIZED IN WRITING BY BS&B PRESSURE SAFETY MANAGEMENT, L.L.C. US AND INTERNATIONAL PATENTS PENDING.

PART LIST IDENTIFICATION

- 1) INPUT ARM
- 2) LATCH
- 3) STOPPER BLOCK
- 4) TRIGGER SUPPORT BLOCK ASSEMBLY
- 5) PISTON GUIDE ROD
- 6) ACTUATOR ASSEMBLY
- 7) TRIGGER
- 8) PIN GUIDE BLOCK
- 9) BUCKLING PIN
- 10) PURGE LINE TUBING
- 11) PIN HOLDER
- 12) PIN ADJUSTER SCREW
- 13) SPRING
- 14) ADJUSTMENT SCREW
- 15) SPRING HUB
- 16) WHITEY VALVE
- 17) HOLE SEAL FOR PISTON GUIDE ROD

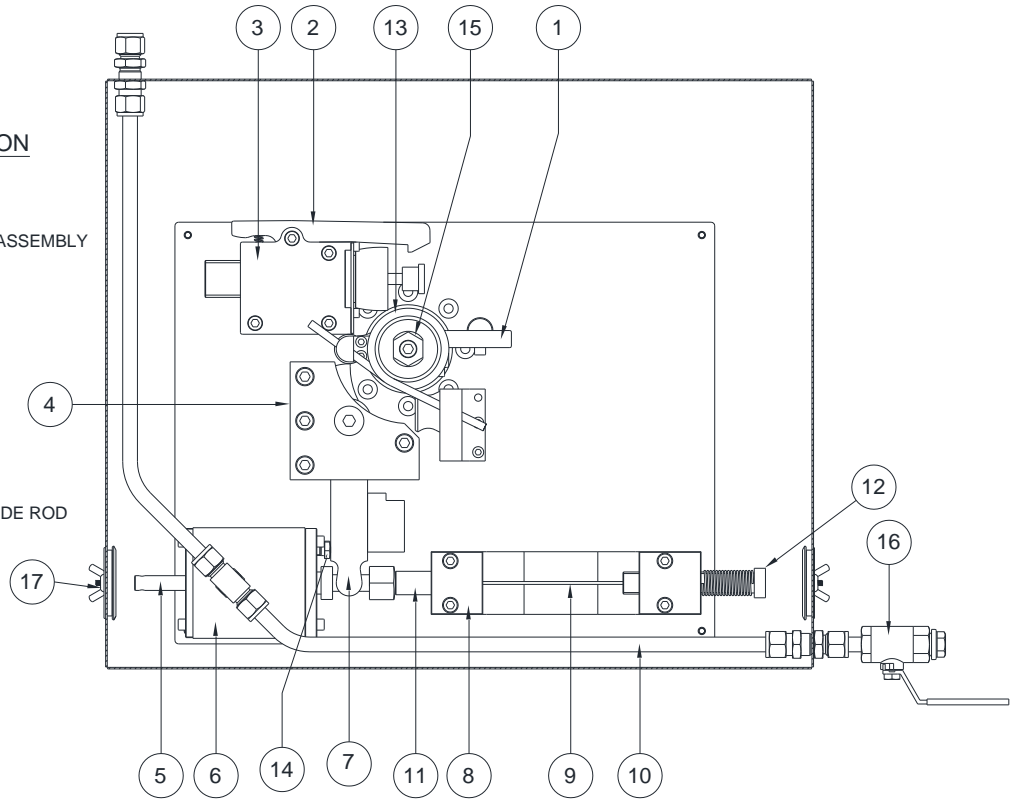

Figure 6(Alternate). Mechanism Assembly (BPIV Closed) - torsion spring

Caution: Do not perform any work inside the mechanism unless the system pressure is verified to be zero, "0psig," upstream and downstream of the valve location and the pilot purge block valve (Whitey valve Item 16) is in the closed position. Failure to do this can cause bodily injury.



SPECIAL ENGINEERING INSTRUCTIONS

DRAWN BY Kunwarani NO. II-MR-0031
CHK'D. BY SIRISH DATE 9-22-11 SHEET 21 OF 32
APP. BY Chank Beau REVISION 0 RELEASE NO. 11-T-0500

| | | | | | | | | | |
|-------|---|----------|-----------|--------|-----------|---------|-----------|-------|-----------|
| REV.: | D | ECN NO.: | 17-T-0107 | DRAWN: | Kunwarani | CHK'D.: | Vasanthan | DATE: | 03-Apr-17 |
|-------|---|----------|-----------|--------|-----------|---------|-----------|-------|-----------|

"PROPRIETARY DATA" IS INCLUDED IN THE INFORMATION DISCLOSED HEREIN AND IS THE SOLE PROPERTY OF BS&B PRESSURE SAFETY MANAGEMENT, L.L.C. THIS INFORMATION IS SUBMITTED IN CONFIDENCE AND NEITHER THIS DOCUMENT NOR THE INFORMATION DISCLOSED HEREIN SHALL BE REPRODUCED OR TRANSFERRED TO OTHER DOCUMENTS OR DISCLOSED TO OTHERS FOR MANUFACTURING OR FOR ANY OTHER PURPOSE EXCEPT AS SPECIFICALLY AUTHORIZED IN WRITING BY BS&B PRESSURE SAFETY MANAGEMENT, L.L.C. US AND INTERNATIONAL PATENTS PENDING.

Buckling Pin Removal and Installation (reference Fig. 6& Fig.6 (Alternate))

1. Close the pilot purge block valve (Whitey valve Item 16) to stop purge pressure / flow on pilot and tubing leading to inlet side of valve body.
2. If the valve is in the closed position with an "inactivated pin", back off pin adjuster screw (Item 12) at least one half inch and remove the "inactivated pin".
3. If the valve is in the open position with an activated pin.
4. Back off pin adjuster screw (Item 12) at least one half inch.
5. Remove the bent used "activated" pin (Item 9).
6. Place a 1" inch socket wrench on the spring hub (Item 15).
7. Lift latch (Item 2) and using socket wrench, rotate input arm (Item 1) clockwise until the bearing on the end of the input arm (Item 1) is touching the stopper block (Item 3). **HOLD THE VALVE CLOSED WITH THE SOCKET WRENCH.**
8. Move the bottom of trigger (Item 7) to the full left piston position touching adjustment screw (Item 14).
9. Place new buckling pin (Item 9) gently into the hole in the center of the pin holder (Item 11).
10. Slowly tighten the pin adjuster screw (Item 12) making sure the end of the buckling pin (Item 9) gently enters the hole in the center of the pin adjuster screw (Item 12).
11. Tighten the pin adjuster screw (Item 12). **DO NOT OVER TIGHTEN THE PIN ADJUSTER SCREW, FINGER TIGHT IS ENOUGH.**
12. Remove the socket wrench holding the valve closed. **DO NOT READJUST PIN ADJUSTER SCREW ONCE SOCKET WRENCH HAS BEEN REMOVED FROM INPUT ARM**
13. Final Check After Pin Installation (refer image 4, image 4 (Alternate)):
 - a. Verify that the bearing end of the input arm (Item 1) is touching the stopper block (Item 3) by using feeler gauge. A gap of .002" maximum is permissible at this location.
 - b. Verify that the top of the trigger (Item 7) is touching the bearing on the end of the input arm (Item 1).
 - c. Verify the trigger (Item 7) is touching Adjustment screw (Item 14).
14. The valve is now ready to return to service. Open the pilot purge block valve (Whitey valve Item 16) to start purge pressure on pilot and tubing leading to inlet side of valve body.



SPECIAL ENGINEERING INSTRUCTIONS

DRAWN BY Kunwarani NO. II-MR-0031
CHK'D. BY SIRISH DATE 9-22-11 SHEET 22 OF 32
APP. BY Chank Beain REVISION 0 RELEASE NO. 11-T-0500

| | | | | |
|---------|--------------------|------------------|-------------------|-----------------|
| REV.: D | ECN NO.: 17-T-0107 | DRAWN: Kunwarani | CHK'D.: Vasanthan | DATE: 03-Apr-17 |
|---------|--------------------|------------------|-------------------|-----------------|

"PROPRIETARY DATA" IS INCLUDED IN THE INFORMATION DISCLOSED HEREIN AND IS THE SOLE PROPERTY OF BS&B PRESSURE SAFETY MANAGEMENT, L.L.C. THIS INFORMATION IS SUBMITTED IN CONFIDENCE AND NEITHER THIS DOCUMENT NOR THE INFORMATION DISCLOSED HEREIN SHALL BE REPRODUCED OR TRANSFERRED TO OTHER DOCUMENTS OR DISCLOSED TO OTHERS FOR MANUFACTURING OR FOR ANY OTHER PURPOSE EXCEPT AS SPECIFICALLY AUTHORIZED IN WRITING BY BS&B PRESSURE SAFETY MANAGEMENT, L.L.C. US AND INTERNATIONAL PATENTS PENDING.

NOTE: PURGING IS ALWAYS REQUIRED FOR FAIL-SAFE OPERATION OF BPIV VALVE. PURGE GAS MUST BE INERT. NITROGEN IS MOST COMMONLY USED PURGE GAS.

15. See approval/certified drawing for purge pressure requirements. Note: **Purge Pressure shall always be more than operating pressure and less than 75% of set pressure unless specified otherwise on approval/certified drawing.**
16. Close the door on the mechanism enclosure for startup.

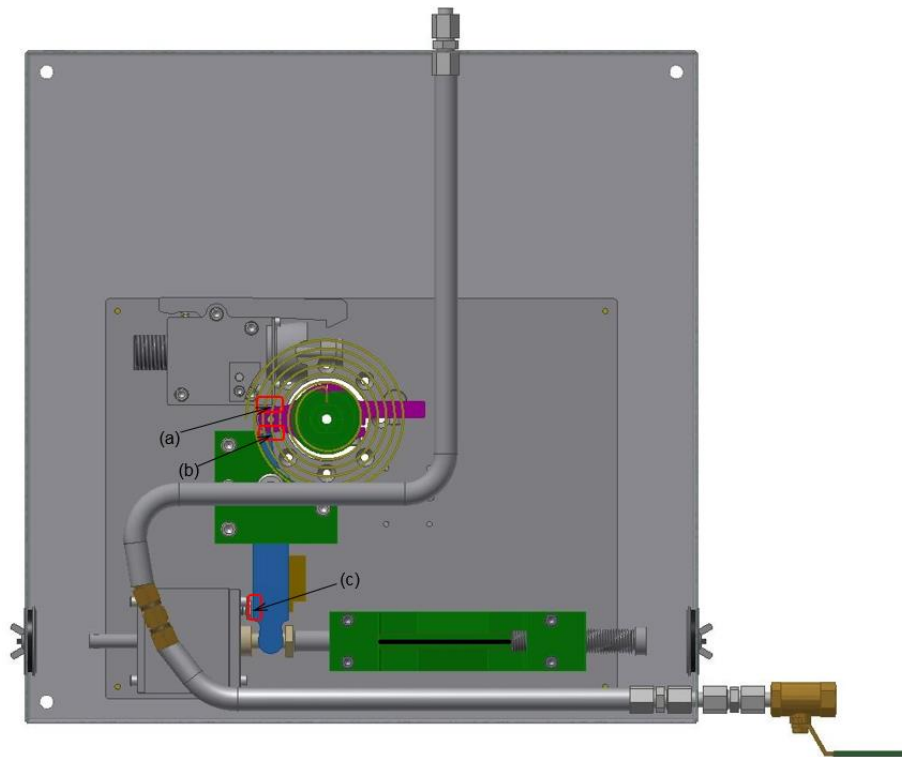

Note: Image – 4 shows the details of check points mentioned above (**clock spring**)



BS&B SAFETY SYSTEMS, L.L.C.

SPECIAL ENGINEERING INSTRUCTIONS

DRAWN BY Kunwarani NO. II-MR-0031
 CHK'D. BY SIRISH DATE 9-22-11 SHEET 23 OF 32
 APP. BY Chand Beain REVISION 0 RELEASE NO. 11-T-0500

| | | | | |
|---------|--------------------|------------------|-------------------|-----------------|
| REV.: D | ECN NO.: 17-T-0107 | DRAWN: Kunwarani | CHK'D.: Vasudevan | DATE: 03-Apr-17 |
|---------|--------------------|------------------|-------------------|-----------------|

"PROPRIETARY DATA" IS INCLUDED IN THE INFORMATION DISCLOSED HEREIN AND IS THE SOLE PROPERTY OF BS&B PRESSURE SAFETY MANAGEMENT, L.L.C. THIS INFORMATION IS SUBMITTED IN CONFIDENCE AND NEITHER THIS DOCUMENT NOR THE INFORMATION DISCLOSED HEREIN SHALL BE REPRODUCED OR TRANSFERRED TO OTHER DOCUMENTS OR DISCLOSED TO OTHERS FOR MANUFACTURING OR FOR ANY OTHER PURPOSE EXCEPT AS SPECIFICALLY AUTHORIZED IN WRITING BY BS&B PRESSURE SAFETY MANAGEMENT, L.L.C. US AND INTERNATIONAL PATENTS PENDING.

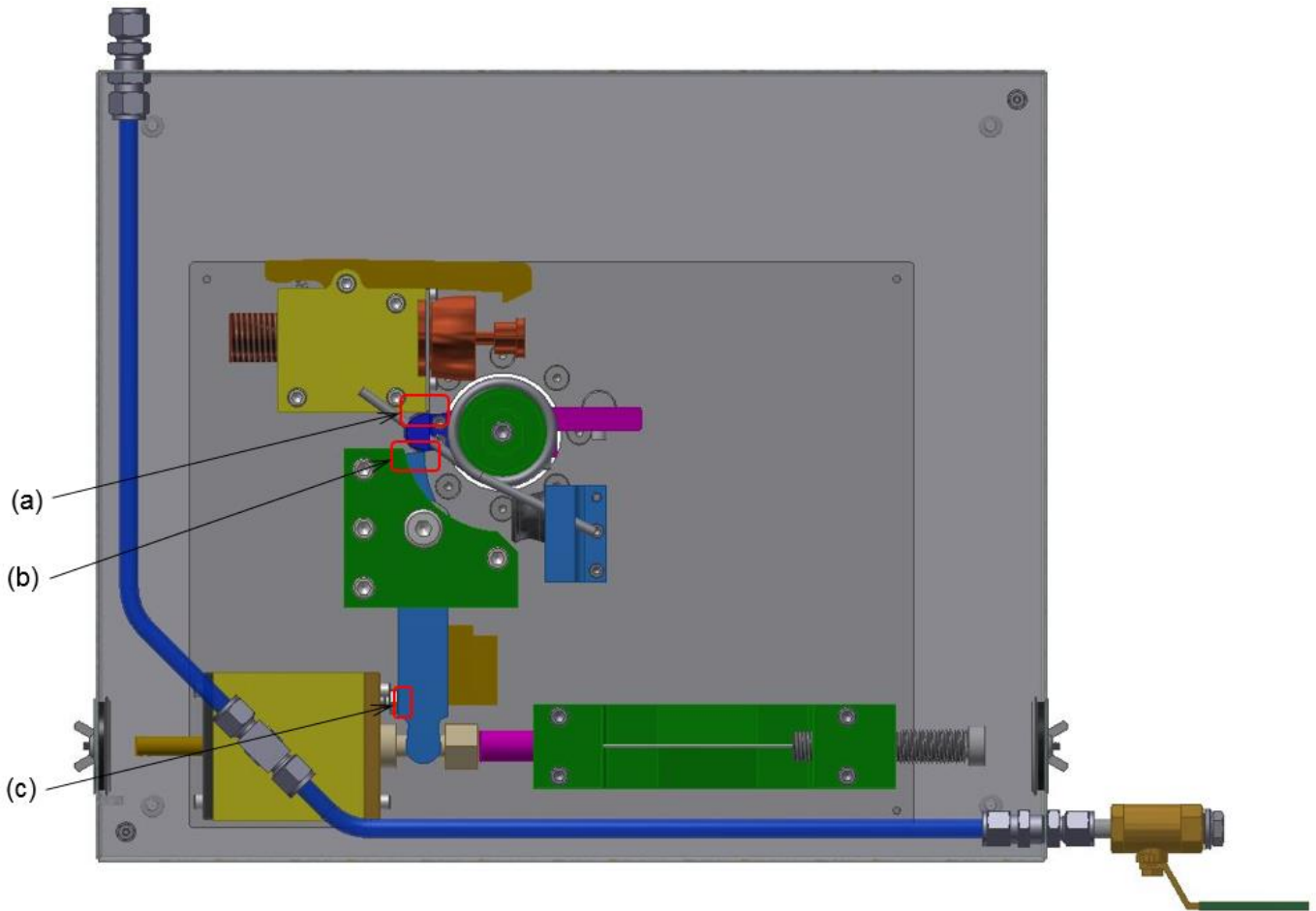

Note: Image – 4(Alternate) shows the details of check points mentioned above (**torsion spring**)

BUCKLING PIN REPLACEMENT ORDERS: Order replacement buckling pins by lot number (shown on pin tag).



BS&B SAFETY SYSTEMS, L.L.C.

SPECIAL ENGINEERING INSTRUCTIONS

DRAWN BY Kunwarani NO. II-MR-0031
 CHK'D. BY SIRISH DATE 9-22-11 SHEET 24 OF 32
 APP. BY Chuck Beair REVISION 0 RELEASE NO. 11-T-0500

| | | | | |
|---------|--------------------|------------------|-------------------|-----------------|
| REV.: D | ECN NO.: 17-T-0107 | DRAWN: Kunwarani | CHK'D.: Vasudevan | DATE: 03-Apr-17 |
|---------|--------------------|------------------|-------------------|-----------------|

"PROPRIETARY DATA" IS INCLUDED IN THE INFORMATION DISCLOSED HEREIN AND IS THE SOLE PROPERTY OF BS&B PRESSURE SAFETY MANAGEMENT, L.L.C. THIS INFORMATION IS SUBMITTED IN CONFIDENCE AND NEITHER THIS DOCUMENT NOR THE INFORMATION DISCLOSED HEREIN SHALL BE REPRODUCED OR TRANSFERRED TO OTHER DOCUMENTS OR DISCLOSED TO OTHERS FOR MANUFACTURING OR FOR ANY OTHER PURPOSE EXCEPT AS SPECIFICALLY AUTHORIZED IN WRITING BY BS&B PRESSURE SAFETY MANAGEMENT, L.L.C. US AND INTERNATIONAL PATENTS PENDING.

MAINTENANCE INSTRUCTIONS FOR BPIV (IN SERVICE PERFORMANCE TEST PROCEDURE)

- The following maintenance instructions shall be done with the BPIV at ambient temperature conditions
- Warning: System pressure upstream and downstream of the valve **MUST NOT** be present during rotational torque testing. Failure to meet this requirement can result in bodily injury, damage to property, pollution and loss of product.
- The following tests shall be carried out after installation of valve into the companion flanges, every time a buckling pin has activated and is being replaced, and during a scheduled shut down or turn around.

In-Line Hydrostatic Test

If in-line hydrostatic test is required with BPIV installed in the system, the valve body tubing to mechanism shall be disconnected by a BS&B Representative to prevent hydro-fluid from entering into the mechanism and pilot. See image 5 (image 5 Alternate) for how this is to be done. After hydrostatic test, a BS&B Representative is to reconnect tubing from the valve body to the mechanism.

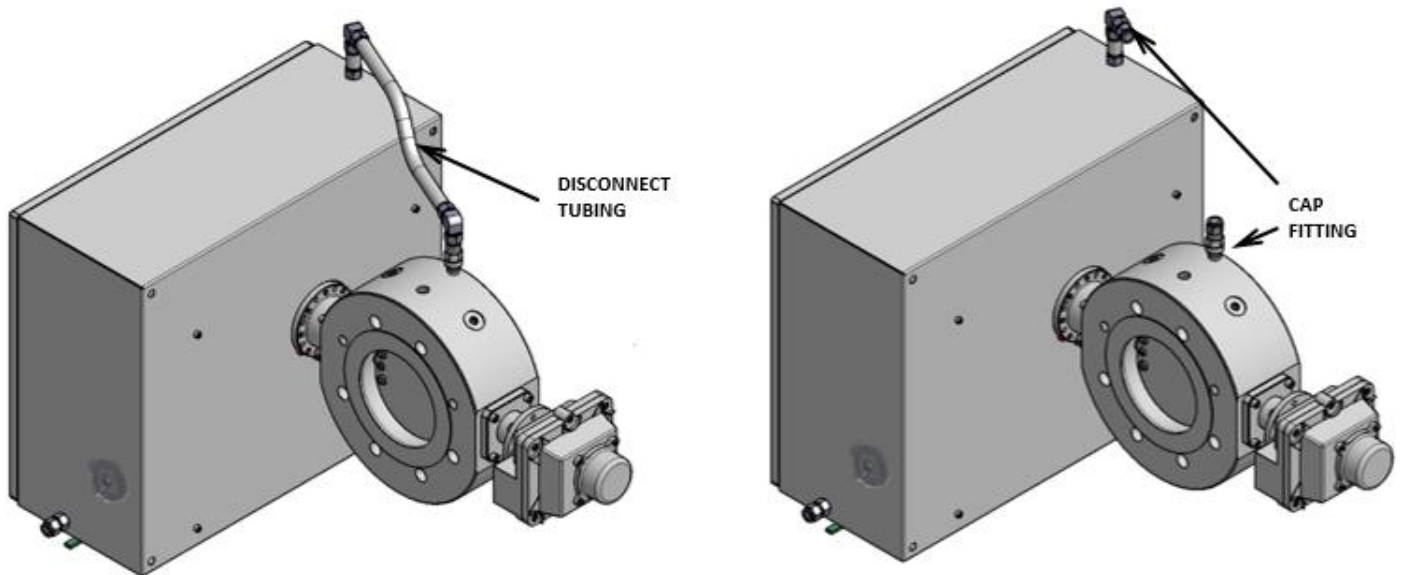

Image – 5: Tubing Connection from Valve to Mechanism



BS&B SAFETY SYSTEMS, L.L.C.

SPECIAL ENGINEERING INSTRUCTIONS

DRAWN BY Kunwarani NO. II-MR-0031
CHK'D. BY SIRISH DATE 9-22-11 SHEET 25 OF 32
APP. BY Chank Beain REVISION 0 RELEASE NO. 11-T-0500

| | | | | | | | | | |
|-------|---|----------|-----------|--------|-----------|---------|----------------|-------|-----------|
| REV.: | D | ECN NO.: | 17-T-0107 | DRAWN: | Kunwarani | CHK'D.: | Vasanthakumari | DATE: | 03-Apr-17 |
|-------|---|----------|-----------|--------|-----------|---------|----------------|-------|-----------|

"PROPRIETARY DATA" IS INCLUDED IN THE INFORMATION DISCLOSED HEREIN AND IS THE SOLE PROPERTY OF BS&B PRESSURE SAFETY MANAGEMENT, L.L.C. THIS INFORMATION IS SUBMITTED IN CONFIDENCE AND NEITHER THIS DOCUMENT NOR THE INFORMATION DISCLOSED HEREIN SHALL BE REPRODUCED OR TRANSFERRED TO OTHER DOCUMENTS OR DISCLOSED TO OTHERS FOR MANUFACTURING OR FOR ANY OTHER PURPOSE EXCEPT AS SPECIFICALLY AUTHORIZED IN WRITING BY BS&B PRESSURE SAFETY MANAGEMENT, L.L.C. US AND INTERNATIONAL PATENTS PENDING.

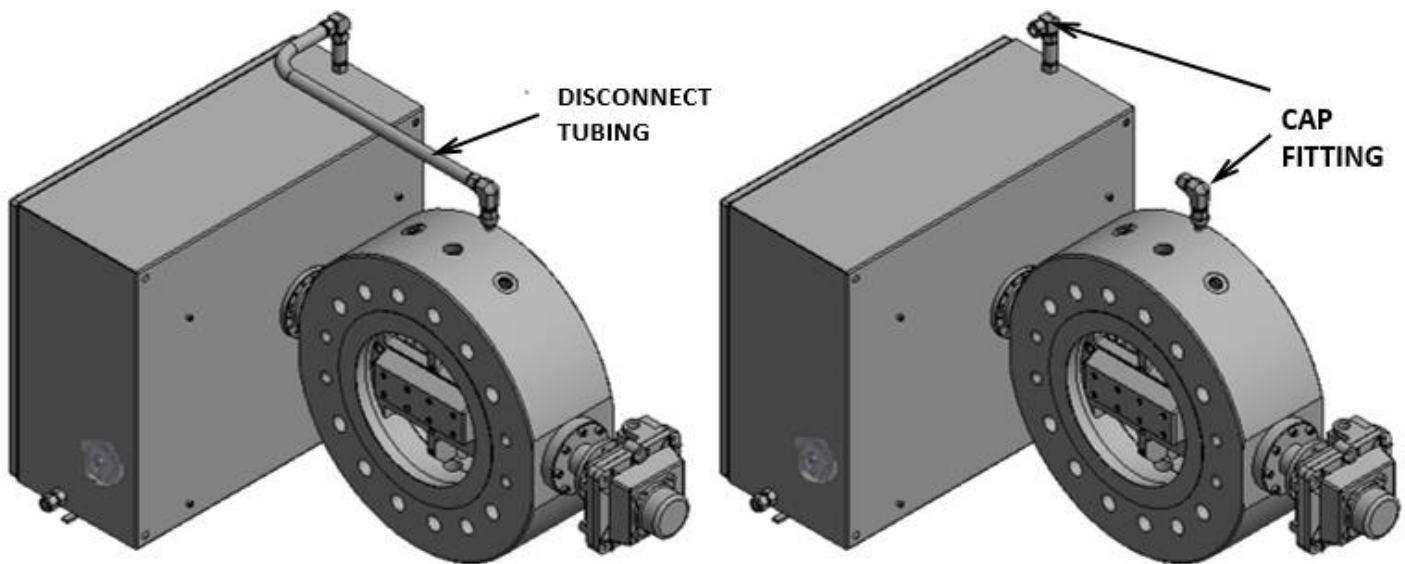

Image – 5: Alternate Tubing Connection from Valve to Mechanism

Pilot System Operation Test (Reference Fig. 6 & Fig.6 Alternate):

WARNING: THE SYSTEM PRESSURE UPSTREAM AND DOWNSTREAM OF THE VALVE MUST BE VERIFIED TO BE ZERO DURING THE ENTIRE PILOT SYSTEM OPERATION TEST. PILOT SYSTEM OPERATION TEST IS TO BE PERFORMED PERIODICALLY NOT LESS THAN ONCE A YEAR.

1. Verify system pressure is at zero upstream and downstream of the valve.
2. Remove the buckling pin (Item 9) per installation instructions taking great care not to damage the pin.
3. If the pin removed in step 2 above was damaged in any way as defined in pin installation instructions, discard pin. If the pin is not damaged, save the pin for re-use **but only if pin tag is still attached.**
4. Place the whitey valve (Item 16) in the closed position, so that the purge gas supply is blocked.
5. Locate and open the Hole seal (Item 17) on the side of the enclosure. This allows the use of the push/pull scale on the piston guide rod (Item 5). The push/pull scale must accurately measure forces between 0-50 pounds of force.
6. If the valve is closed, rotate the valve to the full open and latch position with a 1" socket wrench.



SPECIAL ENGINEERING INSTRUCTIONS

DRAWN BY Kunwarani NO. II-MR-0031
CHK'D. BY SIRISH DATE 9-22-11 SHEET 26 OF 32
APP. BY Chuk Beau REVISION 0 RELEASE NO. 11-T-0500

| | | | | | | | | | |
|-------|---|----------|-----------|--------|-----------|---------|-----------|-------|-----------|
| REV.: | D | ECN NO.: | 17-T-0107 | DRAWN: | Kunwarani | CHK'D.: | Vasanthan | DATE: | 03-Apr-17 |
|-------|---|----------|-----------|--------|-----------|---------|-----------|-------|-----------|

"PROPRIETARY DATA" IS INCLUDED IN THE INFORMATION DISCLOSED HEREIN AND IS THE SOLE PROPERTY OF BS&B PRESSURE SAFETY MANAGEMENT, L.L.C. THIS INFORMATION IS SUBMITTED IN CONFIDENCE AND NEITHER THIS DOCUMENT NOR THE INFORMATION DISCLOSED HEREIN SHALL BE REPRODUCED OR TRANSFERRED TO OTHER DOCUMENTS OR DISCLOSED TO OTHERS FOR MANUFACTURING OR FOR ANY OTHER PURPOSE EXCEPT AS SPECIFICALLY AUTHORIZED IN WRITING BY BS&B PRESSURE SAFETY MANAGEMENT, L.L.C. US AND INTERNATIONAL PATENTS PENDING.

7. With the pilot in the full open position (bottom of trigger counter clockwise to far right piston position), attach the scale to the piston guide rod (Item 5) and measure the pull force to move the piston to the fully closed position (bottom of trigger clockwise to far left piston position). Trigger shall then be touching adjustment screw (Item 14).
8. Push on the scale and the end of the piston guide rod (Item 5) until the trigger (Item 7) rotates to the full open position and measure the push force. Note: If the trigger cannot rotate fully counter clockwise where the trigger (Item 7) and pin holder (Item 11) pushes far right against pin guide block (Item 8), the pilot system may be fouled and need servicing.
9. Observe and record the amount of force needed to move the piston guide rod (Item 5). Repeat the push/pull test 3 times.
10. The force observed in step 9 must be in the range of 0-15 lbs. If it is not, the valve fails this test. Readings above 15 pounds indicate that the pilot system is binding and needs to be serviced. All pull/push readings are to be documented and returned to BS&B Pressure Safety Management, L.L.C.

Valve Rotational Test (Reference Fig. 6 & Fig.6 Alternate):

WARNING: THE SYSTEM PRESSURE UPSTREAM AND DOWNSTREAM OF THE VALVE MUST BE VERIFIED TO BE ZERO DURING THE ENTIRE VALVE ROTATIONAL TORQUE TEST.

1. Close the pilot purge block valve (Whitey valve Item 16) to stop purge pressure / flow on pilot and tubing leading to inlet side of valve body.
2. Verify system pressure is at zero upstream and downstream of the valve.
3. Remove the buckling pin (Item 9) per installation instructions taking great care not to damage the pin.
4. If the pin removed in step 2 above was damaged in any way as defined in pin installation instructions discard pin. If the pin is not damaged, save the pin for re-use, **but only if pin tag is still attached.**
5. Verify that the valve is in the full open position. NOTE: VALVE SHALL ROTATE TO FULL OPEN POSITION AND LATCH DUE TO SPRING TENSION WITH A BUCKLED PIN OR NO PIN. IF VALVE DOES NOT ROTATE TO FULL OPEN POSITION, CONTACT BS&B PRESSURE SAFETY MANAGEMENT.
6. Secure a 1" inch socket and torque wrench to the hex at the center of the Spring Hub (Item 15).
7. Lift latch (Item 2).
8. The spring (Item 13) attached to the Spring Hub (Item 15) shall keep the valve in the open position as noted in note 4. The torque needed to rotate the valve closed will be a combination of the frictional forces in the valve opposing movement, and the spring trying to keep the valve open.
9. The rotation of the valve should be smooth and non-binding.
10. The **Rotational** torque needed to rotate the valve should be _____ ft-lb Maximum until just before the rotating disc contacts the seal. At the time the rotating disc touches the seal, the **Seating (Closing)** torque



SPECIAL ENGINEERING INSTRUCTIONS

DRAWN BY Kunwarani NO. II-MR-0031
CHK'D. BY SIRISH DATE 9-22-11 SHEET 27 OF 32
APP. BY Chank Beau REVISION 0 RELEASE NO. 11-T-0500

| | | | | |
|---------|--------------------|------------------|----------------------|-----------------|
| REV.: D | ECN NO.: 17-T-0107 | DRAWN: Kunwarani | CHK'D.: Vasekthasorn | DATE: 03-Apr-17 |
|---------|--------------------|------------------|----------------------|-----------------|

"PROPRIETARY DATA" IS INCLUDED IN THE INFORMATION DISCLOSED HEREIN AND IS THE SOLE PROPERTY OF BS&B PRESSURE SAFETY MANAGEMENT, L.L.C. THIS INFORMATION IS SUBMITTED IN CONFIDENCE AND NEITHER THIS DOCUMENT NOR THE INFORMATION DISCLOSED HEREIN SHALL BE REPRODUCED OR TRANSFERRED TO OTHER DOCUMENTS OR DISCLOSED TO OTHERS FOR MANUFACTURING OR FOR ANY OTHER PURPOSE EXCEPT AS SPECIFICALLY AUTHORIZED IN WRITING BY BS&B PRESSURE SAFETY MANAGEMENT, L.L.C. US AND INTERNATIONAL PATENTS PENDING.

required to rotate the valve into the fully closed position with the bearing on the end of the input arm (Item 1) touching the stopper block (Item 3) should be _____ ft-lb Maximum. Observe and record these measurements.

11. Rotate the valve from the full closed position with a torque wrench to measure the **Breakaway (Opening)** torque. The proper breakaway torque should be _____ ft-lb Maximum. Observe and record this measurement.
12. If the values of the torques described in step 9 & 10 are within the specified range, then the valve passes this test and may be returned to service per pin installation instructions. If any of the torques exceed their specified range, do not return the valve to service as it may be binding or may need cleaning and/or servicing. Contact BS&B Pressure Safety Management, L.L.C.

MAINTENANCE/INSTALLATION INSTRUCTIONS FOR BPIV MAIN BODY SEAL REPLACEMENT PROCEDURE

These maintenance instructions cover removal and replacement instructions of the main body seal of the BPIV

Frequency of Replacement of Main Body Seal

It is recommended that the main body seal is replaced after twenty-five (25) activations of the valve, this activity is to maintain the leak-tightness of the valve.

It is also recommended that this activity be supervised by an authorized technician from BS&B Pressure Safety Management, L.L.C.

Seal Replacement Kits are required for this activity.

BEFORE YOU INSTALL THE NEW SEAL IN THE BPIV VALVE

Inspect the BPIV Valve

1. Inspect the BPIV valve assembly for foreign materials. Dirt or grit can cause the valve not to seal properly and /or not to operate correctly
2. Inspect the disc sealing surface for damage. It must be free of burrs, nicks and scratches which could cause damage to the new seal.
3. Inspect the mechanism for damage. Damage to the mechanism could cause the valve to open at a pressure other than the rated pressure.
4. Thoroughly and carefully, clean the entire valve assembly.



SPECIAL ENGINEERING INSTRUCTIONS

DRAWN BY Kunwarani NO. II-MR-0031
CHK'D. BY SIRISH DATE 9-22-11 SHEET 28 OF 32
APP. BY Chand Beain REVISION 0 RELEASE NO. 11-T-0500

| | | | | |
|---------|--------------------|------------------|-------------------|-----------------|
| REV.: D | ECN NO.: 17-T-0107 | DRAWN: Kunwarani | CHK'D.: Vasanthan | DATE: 03-Apr-17 |
|---------|--------------------|------------------|-------------------|-----------------|

"PROPRIETARY DATA" IS INCLUDED IN THE INFORMATION DISCLOSED HEREIN AND IS THE SOLE PROPERTY OF BS&B PRESSURE SAFETY MANAGEMENT, L.L.C. THIS INFORMATION IS SUBMITTED IN CONFIDENCE AND NEITHER THIS DOCUMENT NOR THE INFORMATION DISCLOSED HEREIN SHALL BE REPRODUCED OR TRANSFERRED TO OTHER DOCUMENTS OR DISCLOSED TO OTHERS FOR MANUFACTURING OR FOR ANY OTHER PURPOSE EXCEPT AS SPECIFICALLY AUTHORIZED IN WRITING BY BS&B PRESSURE SAFETY MANAGEMENT, L.L.C. US AND INTERNATIONAL PATENTS PENDING.

NOTE: USE A CLEAN SOFT TOWEL ON THE SEALING SURFACE OF THE ROTATING DISC.

5. The BPIV valve must not be machined or modified in any way except with the approval of BS&B Pressure Safety Management, LLC. Failure to obtain such approval voids the warranty on this product.

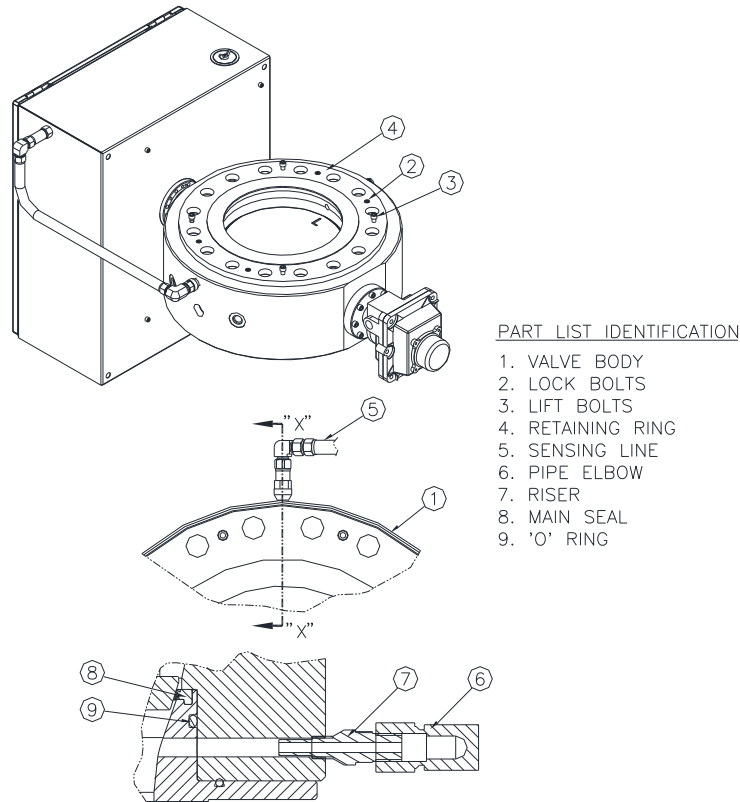

Figure 7 - Typical Seal Replacement.

BPIV Seal Replacement Procedure (Ref Fig.7)

Use of the BPIV seal replacement kit is recommended. It contains appropriate lift bolts.



SPECIAL ENGINEERING INSTRUCTIONS

DRAWN BY Kunwarani NO. II-MR-0031
CHK'D. BY SIRISH DATE 9-22-11 SHEET 29 OF 32
APP. BY Chank Beain REVISION 0 RELEASE NO. 11-T-0500

| | | | | | | | | | |
|-------|---|----------|-----------|--------|-----------|---------|-----------|-------|-----------|
| REV.: | D | ECN NO.: | 17-T-0107 | DRAWN: | Kunwarani | CHK'D.: | Vasanthan | DATE: | 03-Apr-17 |
|-------|---|----------|-----------|--------|-----------|---------|-----------|-------|-----------|

"PROPRIETARY DATA" IS INCLUDED IN THE INFORMATION DISCLOSED HEREIN AND IS THE SOLE PROPERTY OF BS&B PRESSURE SAFETY MANAGEMENT, L.L.C. THIS INFORMATION IS SUBMITTED IN CONFIDENCE AND NEITHER THIS DOCUMENT NOR THE INFORMATION DISCLOSED HEREIN SHALL BE REPRODUCED OR TRANSFERRED TO OTHER DOCUMENTS OR DISCLOSED TO OTHERS FOR MANUFACTURING OR FOR ANY OTHER PURPOSE EXCEPT AS SPECIFICALLY AUTHORIZED IN WRITING BY BS&B PRESSURE SAFETY MANAGEMENT, L.L.C. US AND INTERNATIONAL PATENTS PENDING.

1. Place the BPIV valve in the closed position. Reference the pin installation instructions and install **The Red Shipping Pin** and **The Red Trigger stop spacer** to secure the valve in the closed position.
2. Place the valve assembly on a suitable work surface with the inlet facing up, refer to Figure 7.
3. **DO NOT ALLOW THE MECHANISM ENCLOSURE TO SUPPORT ANY OF THE VALVE ASSEMBLIES WEIGHT.** Use appropriate sized wooden blocks under the valve body (Item 1) to lift and support the weight of the valve body, or allow the mechanism enclosure to overhang the work bench.
4. Remove the retaining ring lock bolts (Item 2) from the valve body (Item 1). Disassemble the inlet pressure sensing line (Item 5) from the pipe elbow (Item 6). Remove the pipe elbow (Item 6) and the riser (Item 7) from the valve body.
5. Follow steps (a) through (n) to replace the main seal (refer to Figure 7).

- (a) Place four lift bolts (Item 3) in the lifting bolt holes in the seal retaining ring (Item 4) and
- (b) Tighten the four lift bolts (Item 3) in the lifting bolt holes in the seal retaining ring (Item 4) all the way through the retainer ring (Item 4) over the body (Item 1) evenly so that retainer ring (Item 4) rises up.

NOTE: THE SEAL RETAINING RING WILL COME OUT EASIER IF THE LIFTING BOLTS ARE EVENLY TIGHTENED.

- (c) Remove the seal retaining ring (Item 4) from the valve body (Item 1). Take care not to damage the O-ring (Item 9) on the outer edge of the seal retaining ring (Item 4) which is present as an emergency backup seal in case of failure of the main body (Item 1) to main seal (Item 8).
- (d) The main seal (Item 8) will be held by the groove on the bottom of the seal retaining ring (Item 4). Pull the main seal (Item 8) from the seal retaining ring (Item 4).
- (e) Clean the main seal retaining ring (Item 4) and check that the new main seal (Item 8) is clean, free from damage, and the correct size for the application. **Note:** Do not machine the main seal (Item 8) if it does not fit. Contact BS&B Pressure Safety Management, LLC.
- (f) Install the new seal (Item 8) in the groove at the bottom of the seal retaining ring (Item 4) by hand. A gentle push into place is all that is required.
- (g) Clean & lubricate the o-ring (Item 9) on the seal retaining ring (Item 4) with a light lubricant suitable for the process application. Set the seal retaining ring (Item 4) into place on the valve body seal end first.
- (h) Remove the lift bolts (Item 3) from retainer ring (Item 4)
- (i) Gently tap the seal retaining ring (Item 4) into the valve body (Item 1) using a soft mallet until the seal retaining ring (Item 4) is flush with the valve body (Item 1). Be sure the hole on the seal retaining ring (Item 4) is lined up properly in order to receive the riser (Item 7).
- (j) Re-install the retaining ring lock bolts (Item 2) and tighten firmly.
- (k) Re-install the riser (Item 7) through the valve body and screw tightly. Now, install the pipe elbow (Item 6) and connect the inlet pressure sensing line (Item 5) back to the pipe elbow (Item 6).



SPECIAL ENGINEERING INSTRUCTIONS

DRAWN BY Kunwarani NO. II-MR-0031
 CHK'D. BY SIRISH DATE 9-22-11 SHEET 30 OF 32
 APP. BY Chand Beain REVISION 0 RELEASE NO. 11-T-0500

| | | | | |
|---------|--------------------|------------------|------------------------|-----------------|
| REV.: D | ECN NO.: 17-T-0107 | DRAWN: Kunwarani | CHK'D.: Vasanthakumari | DATE: 03-Apr-17 |
|---------|--------------------|------------------|------------------------|-----------------|

"PROPRIETARY DATA" IS INCLUDED IN THE INFORMATION DISCLOSED HEREIN AND IS THE SOLE PROPERTY OF BS&B PRESSURE SAFETY MANAGEMENT, L.L.C. THIS INFORMATION IS SUBMITTED IN CONFIDENCE AND NEITHER THIS DOCUMENT NOR THE INFORMATION DISCLOSED HEREIN SHALL BE REPRODUCED OR TRANSFERRED TO OTHER DOCUMENTS OR DISCLOSED TO OTHERS FOR MANUFACTURING OR FOR ANY OTHER PURPOSE EXCEPT AS SPECIFICALLY AUTHORIZED IN WRITING BY BS&B PRESSURE SAFETY MANAGEMENT, L.L.C. US AND INTERNATIONAL PATENTS PENDING.

- (l) Remove the buckling pin from the mechanism. Rotate the disc assembly and cycle the valve through its operational movement several times to make sure that nothing is binding. In the first few degrees of rotation, there will be slight resistance due to seal friction. The remaining motion of the disc should rotate freely and without binding.
- (m) Re-close the valve and replace the pin into mechanism.
- (n) The valve is ready to be re-installed per the "Installation Instruction".

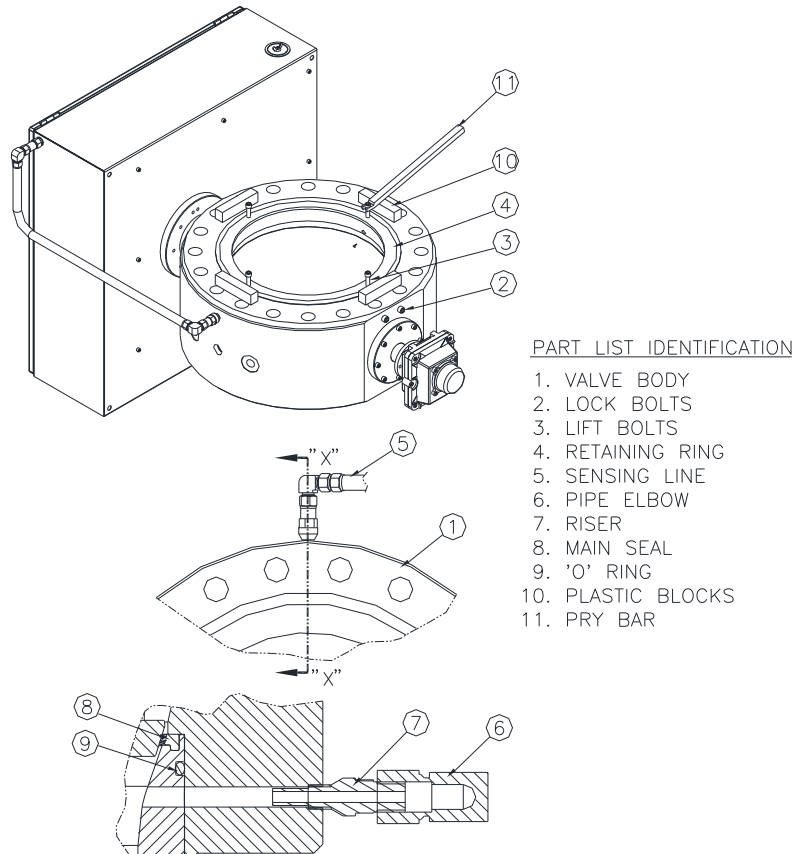

Figure 7 Alternate - Typical Seal Replacement.



SPECIAL ENGINEERING INSTRUCTIONS

DRAWN BY Kunwarani NO. II-MR-0031
CHK'D. BY SIRISH DATE 9-22-11 SHEET 31 OF 32
APP. BY Chank Beain REVISION 0 RELEASE NO. 11-T-0500

| | | | | | | | | | |
|-------|---|----------|-----------|--------|-----------|---------|-----------|-------|-----------|
| REV.: | D | ECN NO.: | 17-T-0107 | DRAWN: | Kunwarani | CHK'D.: | Vasanthan | DATE: | 03-Apr-17 |
|-------|---|----------|-----------|--------|-----------|---------|-----------|-------|-----------|

"PROPRIETARY DATA" IS INCLUDED IN THE INFORMATION DISCLOSED HEREIN AND IS THE SOLE PROPERTY OF BS&B PRESSURE SAFETY MANAGEMENT, L.L.C. THIS INFORMATION IS SUBMITTED IN CONFIDENCE AND NEITHER THIS DOCUMENT NOR THE INFORMATION DISCLOSED HEREIN SHALL BE REPRODUCED OR TRANSFERRED TO OTHER DOCUMENTS OR DISCLOSED TO OTHERS FOR MANUFACTURING OR FOR ANY OTHER PURPOSE EXCEPT AS SPECIFICALLY AUTHORIZED IN WRITING BY BS&B PRESSURE SAFETY MANAGEMENT, L.L.C. US AND INTERNATIONAL PATENTS PENDING.

BPIV Seal Replacement Procedure (Ref Fig.7 Alternate)

Use of the BPIV seal replacement kit is recommended. It contains appropriate lift bolts, plastic blocks, pry bars, or jack plates.

1. Place the BPIV valve in the closed position. Reference the pin installation instructions and install **The Red Shipping Pin** and "**Red Trigger stop spacer**" to secure the valve in the closed position.
2. Place the valve assembly on a suitable work surface with the inlet facing up, refer to Figure 7 Alternate.
3. **DO NOT ALLOW THE MECHANISM ENCLOSURE TO SUPPORT ANY OF THE VALVE ASSEMBLIES WEIGHT.** Use appropriate sized wooden blocks under the valve body (Item 1) to lift and support the weight of the valve body, or allow the mechanism enclosure to overhang the work bench.
4. Cut and remove safety wire from the two retaining ring lock bolts (Item 2). (This safety wire is applied at the time of manufacture & calibration of the BPIV.)
5. Remove the two retaining ring lock bolts (Item 2) from the valve body (Item 1). Disassemble the inlet pressure sensing line (Item 5) from the pipe elbow (Item 6). Remove the pipe elbow (Item 6) and the riser (Item 7) from the valve body (Item 1).
6. Follow steps (a) through (o) to replace the main seal (Item 8) (refer to Figure 7 Alternate).

(a) Place four bolts in the lifting bolt holes (Item 3) in the seal retaining ring (Item 4).

NOTE: THE BOLTS NEED TO BE THREADED ALL THE WAY INTO THE SEAL RETAINING RING, NO MORE THAN FINGER TIGHT. DO NOT TIGHTEN USING A WRENCH.

(b) Place four 1-inch thick plastic blocks (Item 10) next to each lift bolt (Item 3), outside of the seal retaining ring (Item 4) to protect the valve body (Item 1).

(c) Using pry bars (Item 11), gently pry up on the four lift bolts (Item 3) evenly to lift the main seal (Item 8), and seal retaining ring (Item 4) out of the valve body (Item 1).

NOTE: THE SEAL RETAINING RING WILL COME OUT EASIER THE STRAIGHTER IT IS LIFTED OUT OF THE VALVE BODY.

(d) Remove the seal retaining ring (Item 4) from the valve body (Item 1). Take care not to damage the O-ring (Item 9) on the outer edge of the seal retaining ring (Item 4) which is present as an emergency backup seal in case of failure of the main body (Item 1) to main seal (Item 8).

(e) The main seal (Item 8) will be held by the groove on the bottom of the seal retaining ring (Item 4). Pull the main seal (Item 8) from the seal retaining ring (Item 4).

(f) Clean the seal retaining ring (Item 4) and check that the new main seal (Item 8) is clean, free from damage, and the correct size for the application. **Note:** Do not machine the main seal (Item 8) if it does not fit. Contact BS&B Pressure Safety Management, LLC.

(g) Install the new main seal (Item 8) in the groove at the bottom of the seal retaining ring (Item 4) by hand. A gentle push into place is all that is required.



SPECIAL ENGINEERING INSTRUCTIONS

DRAWN BY Kunwarani NO. II-MR-0031
CHK'D. BY SIRISH DATE 9-22-11 SHEET 32 OF 32
APP. BY Chuck Bean REVISION 0 RELEASE NO. 11-T-0500

| | | | | | | | | | |
|-------|---|----------|-----------|--------|-----------|---------|-----------|-------|-----------|
| REV.: | D | ECN NO.: | 17-T-0107 | DRAWN: | Kunwarani | CHK'D.: | Vasanthan | DATE: | 03-Apr-17 |
|-------|---|----------|-----------|--------|-----------|---------|-----------|-------|-----------|

"PROPRIETARY DATA" IS INCLUDED IN THE INFORMATION DISCLOSED HEREIN AND IS THE SOLE PROPERTY OF BS&B PRESSURE SAFETY MANAGEMENT, L.L.C. THIS INFORMATION IS SUBMITTED IN CONFIDENCE AND NEITHER THIS DOCUMENT NOR THE INFORMATION DISCLOSED HEREIN SHALL BE REPRODUCED OR TRANSFERRED TO OTHER DOCUMENTS OR DISCLOSED TO OTHERS FOR MANUFACTURING OR FOR ANY OTHER PURPOSE EXCEPT AS SPECIFICALLY AUTHORIZED IN WRITING BY BS&B PRESSURE SAFETY MANAGEMENT, L.L.C. US AND INTERNATIONAL PATENTS PENDING.

- (h) Clean & lubricate the o-ring (Item 9) on the seal retaining ring (Item 4) with a light lubricant suitable for the process application. Set the seal retaining ring (Item 4) into place on the valve body seal end first.
- (i) Gently tap the seal retaining ring (Item 4) into the valve body (Item 1) using a soft mallet until the seal retaining ring (Item 4) is flush with the valve body (Item 1). Be sure the thread hole on the seal retaining ring (Item 4) is lined up properly in order to receive the riser (Item 7).
- (j) Re-install the two retaining ring lock bolts (Item 2) and tighten firmly. Remove the four lift bolts (Item 3) from the seal retaining ring (Item 4).
- (k) Re-install the riser (Item 7) through the valve body (Item 1) and screw tightly into the seal retaining ring (Item 4) as shown in figure 7 Alternate. Now, install the pipe elbow (Item 6) and connect the inlet pressure sensing line (Item 5) back to the pipe elbow (Item 6).
- (l) Install a safety wire through the two retaining ring lock bolts (Item 2) if facility maintenance procedures require.
- (m) Remove the buckling pin from the mechanism. Rotate the disc assembly and cycle the valve through its operational movement several times to make sure that nothing is binding. In the first few degrees of rotation, there will be slight resistance due to seal friction. The remaining motion of the disc should rotate freely and without binding.
- (n) Re-close the valve and replace the pin into mechanism.
- (o) The valve is ready to be re-installed per the "Installation Instruction".