	<b>Flame Arrester</b> <b>934-BM 150 / 2x0.5</b> <b>Instructions for Operation and Maintenance</b>	REV. 2
		Page 1/6

This Instruction for Operation and Maintenance is applicable for the following flame arrester models:

**Table 1:** Flame Arrester Type

Size	Type	EU-Type Examination Certificate Number
DN150 / 6"	934-BM 150/2x0.5	IBExU16ATEX2105 X

Dimension sheet and pressure drop/volume flow curve are also available on request.

## 1. Use

The Flame Arrester type 934-BM 150/2x0.5 complies with EN ISO 16852:2016 "Flame Arresters-Performance requirements, test methods and limits for use".

The general suitability as a deflagration flame arrester when used with inflammable gas/air mixture and vapour/air mixture of inflammable liquids of the explosion group IIA (MESG  $\geq$  0.9 mm) had been verified by tests executed at the Institute for Safety Technology IBExU Freiberg. The test results were confirmed by the EU-Type Examination certificate **IBExU16ATEX2105 X**.

For all applications and use conditions, the pressure and temperature limits below shall be observed and strictly followed by the end user:

- Maximum Allowable Operating Pressure: Atmospheric (0.8 bar (absolute) to 1.1 bar (absolute))
- Maximum Allowable Operating Temperature: -20°C to 60°C

As part of the documentation package, the product is delivered with a factory Test Certificate according to EN 10204, which includes the technical features of the product as well as the EU-Type Examination certificate number.

Also, as part of the documentation package, a Declaration of Conformity is issued, assuring compliance with standards EN ISO 16852 and EN 1127-1, as well as compliance with the ATEX directive 2014/34/EU.

## 2. Construction

The Flame Arrester 934-BM 150/2x0.5 is basically consisted of a Housing (1), Element Bank (4), Holding Bolts and Nuts (2 & 11), Weatherhood (12), Fusible Element (13), Wing Screw (14) and Torsion Springs (16 & 17). The Housing (1) is provided with Stud Bolts and Nuts (2 & 11)), which are used to attach the Element Bank to the Housing.

The Element Bank is made of two Arrester Elements, which have different winding directions.

The Arrester Elements are produced with a gap width of 0.5mm.

For protection against weather effects, the Flame Arrester is equipped with a Weatherhood, that is held by the Wing Screw.

Inside the Weatherhood the unit has a Fusible Element to which the Wing Screw is connected. The Fusible Element is designed to be melted in a situation of Endurance Burning. In this event the unit is designed to have its Weatherhood pushed and kept open by the Torsion Springs, allowing the gas mixture to be freely burnt to the atmosphere.

Created By:	Tiago Freitas	Date: 08/12/21	<b>BS&amp;B FlameSAF Limited, Limerick, Ireland</b>
Approved By:	B. Murphy	Date: 08/12/21	

	<b>Flame Arrester</b> <b>934-BM 150 / 2x0.5</b>	<b>REV. 2</b>
	<b>Instructions for Operation and Maintenance</b>	<b>Page 2/6</b>

### 3. Marking

The product is supplied with nameplate(s) and label(s) that provide important information to the customer about the product and its limitations. Below are some of the information provided:

Nameplate:

- Name and address of the Manufacturer
- Product Type (including version number)
- Serial Number and year of manufacture
- EU-Type Examination Certificate Number
- Number of the relevant design standards (ISO 16852)
- EX mark, followed by the device group information II and the letter "G" (for classified areas where explosive gases, vapors and/or air mixtures are present)
- Explosion group
- CE mark, followed by the Notified Body number

Warning Label:

- **Warning Flame arresters have installation and application limits**  
**Type designation in accordance with ISO 16852**
- Characters for Flame Arrester Type: **DEF** (Deflagration)
- $L_v/D$  Ratio (distance to ignition source): --- (Not applicable)
- Burn rating "BC": **a** (Endurance burning)
- Burning Time  $t_{BT}$  (only for "BC" b): --- (Not applicable)
- Explosion Group: **IIA**
- Maximum Operational Temperature  $T_0$ : **60°C**
- Maximum Operational pressure  $p_0$ : **atm.** (Atmospheric)

Informative Label:

Note: This flame arrester is safe for endurance burning! The use is restricted to pure hydrocarbons!  
Refer to operating and maintenance instructions!

The Arrester Elements are marked at the outside with the following information:

- Name of the manufacturer
- Gap width
- Material designation number
- Winding direction

Example: **BS&B-0.5-1.4571-R**

<b>Created By:</b>	<b>Tiago Freitas</b>	<b>Date:</b> 08/12/21	<b>BS&amp;B FlameSAF Limited, Limerick, Ireland</b>
<b>Approved By:</b>	<b>B. Murphy</b>	<b>Date:</b> 08/12/21	

	<b>Flame Arrester</b> <b>934-BM 150 / 2x0.5</b> <b>Instructions for Operation and Maintenance</b>	<b>REV. 2</b>
		<b>Page 3/6</b>

#### 4. Installation

The pipeline arrangement is defined by the customer and the installation of the Flame Arrester shall be conducted by the customer following this IOM and the applicable standards. The customer shall observe the requirements and limitations of use, outlined on the applicable standards.

The unit shall be installed in the Vertical orientation.

Before installation, customer must make sure the sealing surfaces are in perfect condition and free from any foreign objects, oil, or grease. Appropriate gaskets and torque shall be applied for a proper and leak tight installation. The unit shall only be lifted by the Lifting Lugs/Eye nuts provided with the unit and never by the Weatherhood.

Customer shall maintain a safe clearance between the Flame Arrester and any other object/obstacle that may obstruct the unit venting area and may affect its flow capacity. Customer shall evaluate operating conditions and establish a safe clearance distance and shall take into the account the clearance needed for the movement of the Weatherhood during its opening.

As the 934-BM is designed for Endurance Burning, the customer shall make sure that there are no obstructions to the flame when the unit is in combustion activity and shall make sure that the combustion activity doesn't take place in closed spaces where the temperature may rise without control and shall take measures to prevent that the heat, gases and vapours resulted from the combustion can cause harm to anyone in the surroundings.

The unit shall be installed to customer connection using flanges/connections technically equivalent to the one provided on the unit and in fit working conditions. Appropriate seal/gaskets may be installed between the flame arrester and the customer connection to provide sealing.

The unit may be shipped with the Weatherhood secured by adhesive tape and with the Wing Screw removed, this approach is adopted to prevent damage to the Fusible Element during transport and installation. Once the unit is installed to its operating position, the Wing Screw shall be installed to secure the Weatherhood, and the adhesive tape shall be removed before operation.

#### 5. Maintenance

Customer shall perform periodic visual inspections to the Flame Arrester, to check if the unit presents any signs of damage and/or contamination.

The frequency of the inspections is dependent on the type of process fluid and operating conditions of the Flame Arrester; Therefore, the frequency of inspections/maintenance shall be established by the customer/end user.

The Element Bank (4) of the Flame Arrester element shall be replaced if 30% or more of its venting area is contaminated or blocked.

During the periodic inspections, if light contamination is found, the Arrester Elements can be cleaned by blowing compressed air or hot vapor in the opposite direction of the normal flow direction of the Arrester Elements. Below are instructions to how to remove the Element Bank for cleaning the Arrester Elements:

1. First the Weatherhood (12) must be held securely in place and the Wing Screw (14) shall be carefully removed.
2. **Caution: DO NOT** remove the wing screw before securing the Weatherhood or the Weatherhood can hit the person performing the work as it is loaded by the torsion springs. Only remove the Wing Screw if you have the Weatherhood held during the entire time.
3. After the Wing Screw is removed, the Weatherhood shall be carefully lifted to the open position until it loses the load of the springs and shall be kept open.
4. Now, with access to the internals, the nuts (11) shall be removed and after that the Element Bank can be removed and both sides can be cleaned.

<b>Created By:</b>	<b>Tiago Freitas</b>	<b>Date:</b> 08/12/21	<b>BS&amp;B FlameSAF Limited, Limerick, Ireland</b>
<b>Approved By:</b>	<b>B. Murphy</b>	<b>Date:</b> 08/12/21	

	<b>Flame Arrester</b> <b>934-BM 150 / 2x0.5</b>	<b>REV. 2</b>
	<b>Instructions for Operation and Maintenance</b>	<b>Page 4/6</b>

If heavy contamination is present, a cleaning agent or detergent may be used, taking great care not to damage or deform the Arrester Elements gaps. After cleaning is complete, make sure the Flame Arrester is clean and dry before installation.

If the Arrester Elements present any signs of damage or have more than 30% of its flow area contaminated, then it needs to be replaced by a new one. To disconnect the Weatherhood from the Element Bank, these steps may be followed:

1. Remove the circlips that secure the Springs Shaft (15) in place.
2. Remove the Springs Shaft from the Element Bank and the Springs and Weatherhood will be detached from the Element Bank.

The Arrester Element shall also be replaced if any of the situations below occur:

- If any fire/combustion activity occurs to the Element Bank.
- If the Arrester Element ribbons start getting loose or deformed.
- If corrosion on the Arrester Elements or on the Element Bank is detected.
- If even after cleaning the Arrester Element still has 30% or more of its flow area contaminated/blocked.

**Note:** The Element Bank is a single component and shall never be dismantled or modified in anyway as this will cause damage to the Arrester Elements, that are installed inside the Element Bank.

For the installation of a new Element Bank, the same assembly steps shall be followed but in the reverse order.

**Note:** Thread locker Loctite 221 (or technically equivalent) shall be applied to the nuts and bolts before their installation.

Care shall be taken not to damage the Element Bank during or prior installation. After completing the installation customer shall make sure the Arrester Elements are free from any damage.

The torque on the nuts and bolts shall be checked at every periodic inspection and rectified as appropriate.

All maintenance works on the unit shall only be performed by qualified and trained personnel.

It is recommended to always keep one spare Element Bank in stock for each unit in operation.

Only genuine parts, supplied by BS&B FlameSaf Ltd, may be used for any maintenance/repair work performed on the Flame Arrester. Please refer to Table 1 (Spare Parts List) for the part numbers to be used to re-order parts.

<b>Created By:</b>	<b>Tiago Freitas</b>	<b>Date:</b> 08/12/21	<b>BS&amp;B FlameSAF Limited, Limerick, Ireland</b>
<b>Approved By:</b>	<b>B. Murphy</b>	<b>Date:</b> 08/12/21	

## 6. Spare Parts List

Item No	Designation	Qty Needed / Flame Arrester	Material	Order Number
1	Housing ANSI CL150# Connection	1	SS	992580000
1	Housing ANSI CL150# Connection	1	CS	992579000
1	Housing EN 1092-1 PN10/16 Connection	1	SS	992578000
1	Housing EN 1092-1 PN10/16 Connection	1	CS	992577000
2	Stud Bolt	8	SS	312041000
4 *	Element Bank	1	SS	FET960000503
11	Hex Nut	8	SS	202040839
12	Weatherhood	1	SS	992191500
13 *	Fusible Element	1	Eng. Plastic	992205000
14 *	Wing Screw	1	SS	202062500
15	Springs Shaft	1	SS	960000506
16 *	Torsion Spring-R	1	SS	532006400
17 *	Torsion Spring-L	2	SS	532006500

**Table 2: Spare parts List**

**Notes:**

- \* Essential parts for periodic preventive maintenance
- CS = Carbon Steel
- SS = Stainless Steel

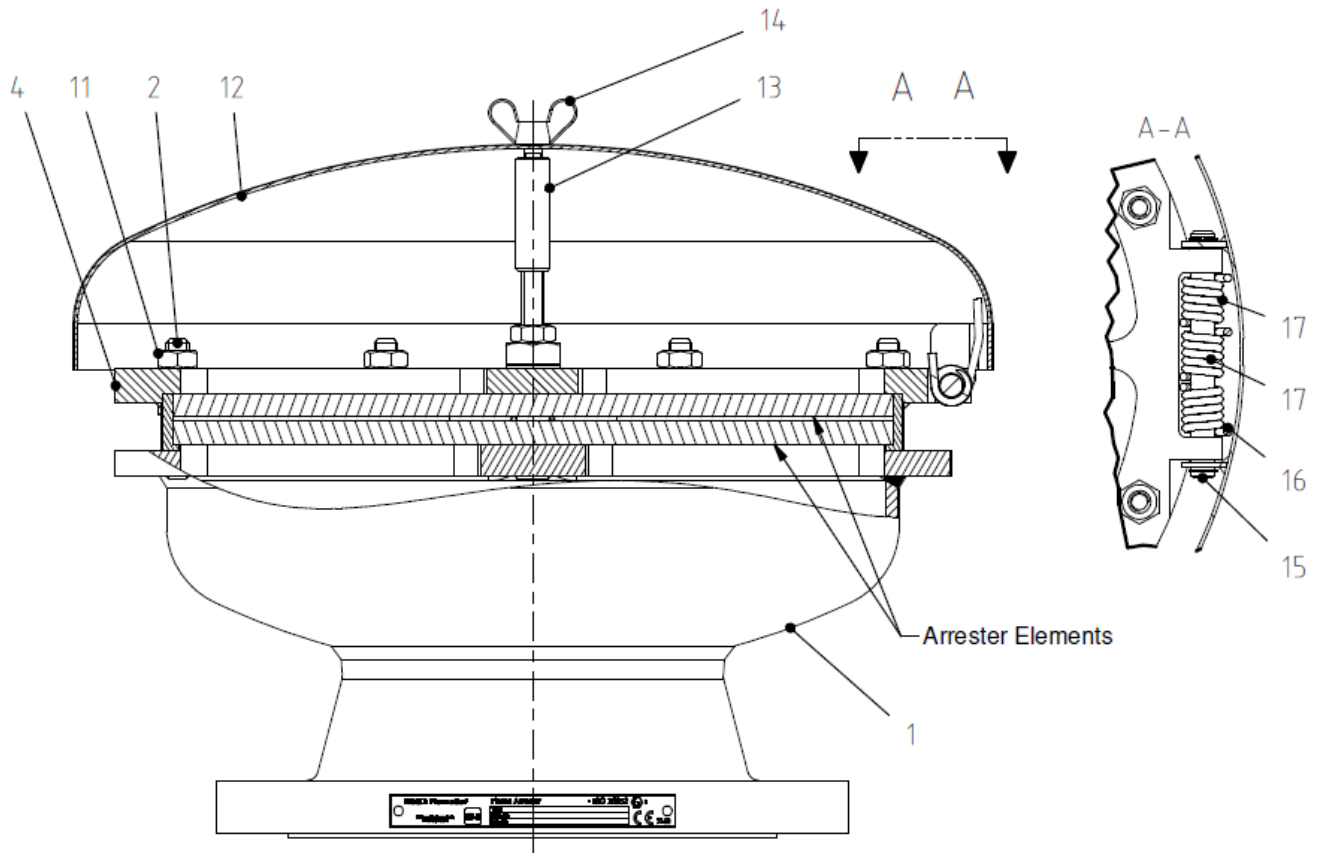

**Figure 1 – Components Identification Drawing**

<b>Warning</b>		Flame arrester have installation and application limits. Type design in accordance with ISO 16852	
DEF	$L_u/D =$	BC:	$t_{BT} = \text{--- min}$
	Ex G	$T_0 =$ °C	$p_0 = \text{atm.}$

**Figure 2 – Warning Label**

Note: This flame arrester is safe for endurance burning! The use is restricted to pure hydrocarbons! Refer to operating and maintenance instructions!

**Figure 3 – Informative Label**

**Note:** The labels and nameplates shown in this page are shown for identification purposes only, please refer to page 2 and to the product certificates and tags for the unit operating limits.

<b>Created By:</b>	<b>Tiago Freitas</b>	<b>Date:</b> 08/12/21	<b>BS&amp;B FlameSAF Limited, Limerick, Ireland</b>
<b>Approved By:</b>	<b>B. Murphy</b>	<b>Date:</b> 08/12/21	