



FLAME ARRESTER
934-BM 80(65)/0320k1/05/et
INSTRUCTIONS FOR OPERATING AND MAINTENANCE

REV 1.0

Page 1/5

For the flame arrester (FDS) type 934-BM 80(65)/0320k1/05/et dimension sheet and pressure drop/volume flow diagram are available.

1. Use

The flame arrester type 934-BM 80(65)/0320k1/05/et complies with the standard EN ISO 16852:2016 "Flame Arresters-Performance requirements, test methods and limits for use".

The general suitability as a deflagration- endurance-burn flame arrester when used with inflammable gas/air mixture and vapour/air mixture of inflammable liquids of the explosion group IIB (gap $\geq 0,5$ mm) and ethyl alcohol had been verified by tests executed at the Institute for Safety Technology IBExU Freiberg. The results of it were confirmed by the issued EC prototype test certificate **IBExU16ATEX2018 X**.

It has to be considered that the safe use of hydrocarbons and ethyl alcohol is restricted, and an extension of the usage onto other chemicals needs special testing.

On principle, for all cases of use the placement conditions, especially the following limits for the operating pressure and temperature have to be considered:

- permissible operating pressure : atmospheric (0,8bar (absolute) to 1,1bar (absolute))
- permissible operating temperature : -20°C to 60°C

On delivery of the devices the technical parameter of the flame arrester with stating the EC prototype test certificate number are documented in the works test certificate according to EN 10204.

In the declaration of compliance it is referred to the accordance with the harmonized standard EN ISO 16852. The maintenance of the basic safety requirements according to directive 2014/34/EU has been confirmed.

2. Construction

The FDS type 934-BM 80(65)/0320k1/05/et consists of a housing of cast steel (1), in which a flame arrester element (4) above set screws (2) and hexagon nuts (11) is clamped. The flame arrester itself consists of a covering flange, a grid cage, a star and two metal foil elements. The foil elements have different directions of winding in its gaps. The upper metal foil element is 20 mm wide, the gap width amounts 0.3 mm. The lower metal foil element is 10 mm wide, the gap width amounts 0.5 mm. For protection against effects of the weather the flame arrester is equipped with a metal sheet cover (12). In case of endurance burning a clamp of acryl glass (13) will burn down. The metal cover will be opened by torsion springs (15) and (16). That is why an unhindered burning down of the inflammable mixture will be possible.

3. Marking

The information for marking the flame arrester is arranged on the nameplate, the hazard sign and an additional hazard sign (page 4/4).

The following data are indicated:

nameplate

- name and address of the manufacturer
- type (including version number)
- serial number and year of production
- number of the certificate (EC prototype certificate-no.)
- number of relevant standard – ISO 16852
- specific mark for prevention of explosions in connection with the mark indicating the group of devices II, and the letter "G" (for areas where explosive gas, vapour, air mixtures are available)
- explosion group

Created By:	RMG	Date: 01.01.14	BS&B FlameSaf Limited, Limerick, Ireland
Approved By:	D. Hennessy	Date: 01.01.14	



FLAME ARRESTER
934-BM 80(65)/0320k1/05/et
INSTRUCTIONS FOR OPERATING AND MAINTENANCE

REV 1.0

Page 2/5

– CE mark with the number of the indicated inspection authority, which act during production hazard sign

– **Warning Flame arresters have installation and application limits**

Type designation in accordance with ISO 16852

- | | | |
|--|----------------------|---------------------|
| – sign for type of flame arrester: | DEF | (deflagration) |
| – ratio L_u/D (distance to ignition source): | --- | (not applicable) |
| – burn rate „BC“: | a | (endurance burning) |
| – burn time t_{BT} (only for „BC“ b): | --- | (not applicable) |
| – explosion group: | IIB + Ethanol | |
| – operational temperature T_o : | 60°C | |
| – maximum operational pressure p_o : | atm. | (atmospheric) |

warning note

Note: The use is restricted to pure hydrocarbons and methanol/ethanol!
Pay attention to instructions for operating and maintenance!

The metal foil is marked at the outermost wound element, as follows:

- name of the manufacturer
- gap width
- material number
- direction of winding

example: BS&B – 0,5 – 1.4571 – R

4. Installation

The arrangement and the installation of the flame arrester into the plant shall be done under observance of the rules applicable to the relevant range of use. Especially the instructions for accident prevention have to be observed. A vertical installation position of the flame arrester has to be kept under any circumstances.

A minimum distance of outlet to external devices has to be adhered, to avoid reduction of volume flow resp. to avoid damage due to flame causing by endurance burning.

This minimum distance depends on local circumstances and has to be specified by operator.

Flame arrester for endurance burning must not be equipped with heat insulation.

In flange version the FDS is equipped with a flange DN80 (DN65) PN16 – shape C or 3" (2 ½) ANSI 150 RF. During flanging pay attention that the sealing face is not damaged and that there is no foreign matter or dirt between the flanges so that a gap effect towards the atmosphere cannot arise.

5. Maintenance

The maintenance includes a periodic visual control of the flame arrester, especially the flame arrester element with regard to contamination and appearance. The intervals for the maintenance works depend on the operating conditions and the kind how the individual media tend to contamination. They are determined by the operator.

For the purpose of cleansing the flame arrester element shall be dismantled:

The metal sheet cover (12) had to let by loosening the wing bolt (14).

Created By:	RMG	Date: 01.01.14	BS&B FlameSaf Limited, Limerick, Ireland
Approved By:	D. Hennessy	Date: 01.01.14	



FLAME ARRESTER
934-BM 80(65)/0320k1/05/et
INSTRUCTIONS FOR OPERATING AND MAINTENANCE

REV 1.0

Page 3/5

(pay attention: Torsion springs will be strained.)

The flame arrester element (4) with metal sheet cover can be dismantled by loosening the hexagon nuts (11).

In case of minor contamination the flame arrester element shall be blown up with compressed air or hot vapour. In case of major contamination a flushing with a cleaning agent can be carried out. After cleansing all parts which had been wetted by a cleansing agent; shall be blown dry.

The single metal foil elements of the flame arrester (3) shall not be removed from its housing parts.

The installation of the flame arrester and housing is carried out in reverse order.

During the cleansing works no mechanical modifications may be done on the flame arrester element or on the housing parts of the flame arrester.

On principle, the flame arrester element has to be replaced by a new one, if:

- a fire occurred at the flame arrester element;
- loosening or distortions in the structure of the metal foil elements can be recognized;
- corrosion damages at the metal foil elements have been detected;
- in case of strongly contaminated metal foil elements, even after cleaning, a residual contamination of more than 30 % of the free flow cross-section remained.

All works in connection with the replacement of metal foil elements in a flame arrester element shall be executed only by trained and authorized skilled personnel.

It is recommended to hold a spare flame arrester element ready for each flame arrester.

In case of replacement of structural units only original spare parts listed in the spare parts list may be installed to ensure the required safety.

Created By:	RMG	Date: 01.01.14	BS&B FlameSaf Limited, Limerick, Ireland
Approved By:	D. Hennessy	Date: 01.01.14	



FLAME ARRESTER
934-BM 80(65)/0320k1/05/et
INSTRUCTIONS FOR OPERATING AND MAINTENANCE

REV 1.0

Page 4/5

6. Spare part list

Table : Spare parts 934-BM 80(65)/0320k1/05/et

Item No.	Designation	No.	Material	Order-No.
4	Flame arrester element 0320k1/05	1	NSt	FET15334391
13	Clamp	1	K	FET992181000

Material marks

St ... steel

NSt ... stainless steel

K ... plastic (acryl glass)

Created By:	RMG	Date: 01.01.14	BS&B FlameSaf Limited, Limerick, Ireland
Approved By:	D. Hennessy	Date: 01.01.14	



FLAME ARRESTER
934-BM 80(65)/0320k1/05/et
INSTRUCTIONS FOR OPERATING AND MAINTENANCE

REV 1.0

Page 5/5

Assembly Drawing

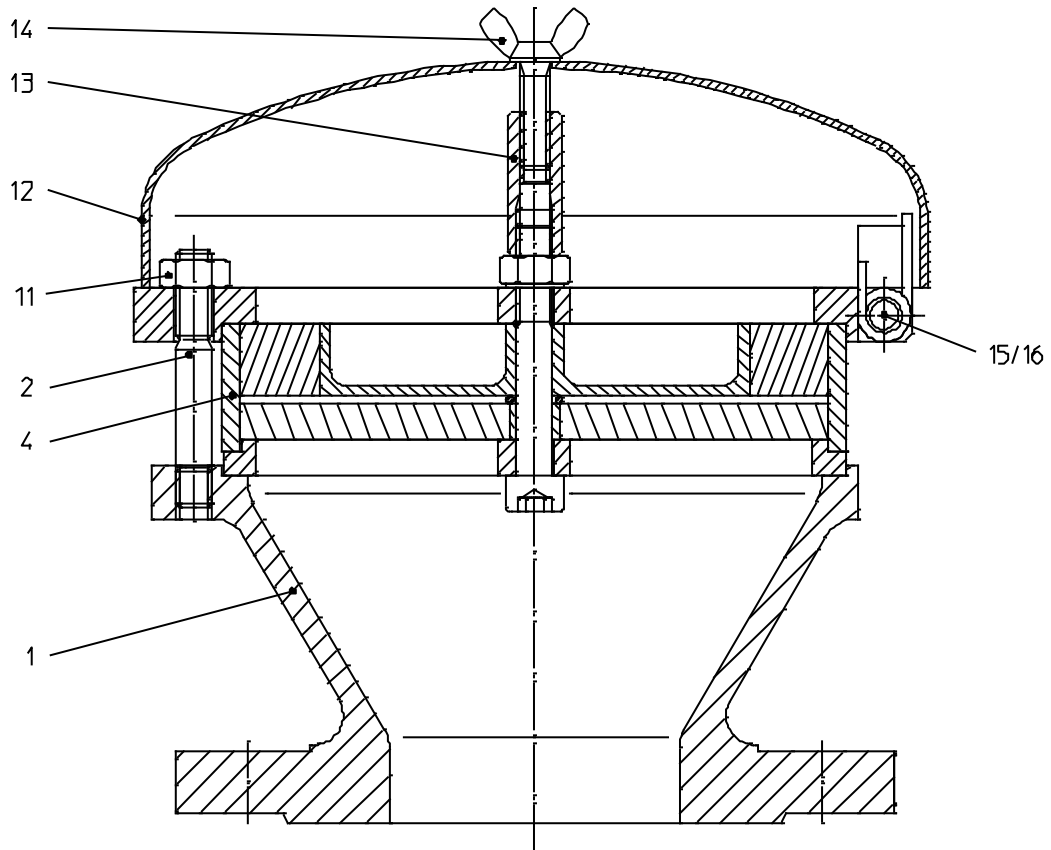

Hazard sign

Warning installation and application limits in accordance with ISO 16852			
DEF	$L_{ij}/D = \dots$	BC : a	$I_{BT} = \dots$
	Ex. G IIB+EI	$T_0 = 60^\circ\text{C}$	$p_0 = \text{atm.}$

Warning note

Note: The use is restricted to pure hydrocarbons and methanol/ethanol
Pay attention to instructions for operating and maintenance

Created By:	RMG	Date:	01.01.14	BS&B FlameSaf Limited, Limerick, Ireland
Approved By:	D. Hennessy	Date:	01.01.14	