	<b>Pressure vent 935 50/2x0.5</b>	<b>REV 1.0</b>
	<b>Instructions for operating and maintenance</b>	<b>Page 1/7</b>

For the deflagration and endurance burning proof pressure vent type 935-50/2x0,5 catalogue data sheets as "Dimension sheet", "Technical data" and "Pressure drop/volume flow charts" are available including the technical data, constructions and dimensions.

## 1. Use

Pressure vent 935-50/2x0,5 complies with standards  
 EN ISO 16852:2016 Flame Arresters – Performance requirements, test methods and limits for use  
 DIN EN 13463 Non-electrical equipment for potentially explosive atmospheres  
 - Part 1: Basics methods and requirements: 2009 - 07  
 - Part 5: Protection by constructional safety "c": 2004 - 03

The general suitability as a deflagration and endurance burning proof end-of-line flame arrester when used with inflammable gas/air mixtures and vapour/air mixtures of inflammable liquids of explosion group IIA (standard gap width > 0.9 mm) been verified by tests executed at the Institute for Safety Technology IBExU GmbH Freiberg and the results were confirmed by the issued EC prototype test certificate **IBExU19ATEX2088 X**.

To be attend is a safe use just for pure hydrocarbons. It needs to be tested to use this flame arrester for other chemical vapours.

In principle, for all cases of use the placement conditions, especially the following limits for the operating pressure and temperature have to be considered:

- ⑩ maximum permissible operating pressure : 1,1 bar (absolute)
- ⑩ maximum permissible operating temperature : 60°C  
(surface temperature max. 80% of ignition point)

The following valve insert settings are possible :

- ⑩ Set-pressure for pressure: 2,5 bis 50 mbar \*) \*) factory pre-set default

On delivery of the devices the technical parameter of the flame arrester with stating the EC prototype test certificate number are documented in the works test certificate according to EN 10204. In the declaration of compliance it is referred to the accordance with the harmonized standard ISO 16852. The maintenance of the basic safety requirements according to directive 2014/34/EU has been confirmed.

## 2. Construction

The Vent 935 consists of a cast iron housing (1), equipped with a pressure valve insert (15) and a flame arrester element (2).

The flame arrester itself consists of a covering flange, a grid cage, a star and two metal foil elements. The foil elements have different directions of winding. The metal foil elements are 10 mm wide with a gap width of 0.5 mm. For protection against effects of the weather the flame arrester is equipped with a metal sheet cover (21). It will be opened by torsion springs to keep free the space for the inflammable mixture. For emptying of condensate the vent is equipped with a condensate screw (40) with thread M10x1.

The valve insert is pre-set for the customer's specific set-up pressure via weight discs at the manufacturer's end. They can either be equipped with FEP sealing foil or with a valve disc with a metallic sealing surface.

<b>Created By:</b>	<b>RMG</b>	<b>Date: 01.01.14</b>	<b>BS&amp;B FlameSAF Limited, Limerick, Ireland</b>
<b>Approved By:</b>	<b>VOH</b>	<b>Date: 15.07.19</b>	

	<b>Pressure vent</b> <b>935 50/2x0.5</b>	<b>REV 1.0</b>
	<b>Instructions for operating and maintenance</b>	<b>Page 2/7</b>

### 3. Marking

The information for marking the vent are arranged on the nameplate (page 7/7).  
The following data are indicated:

- ☞ Name and address of the manufacturer
- ☞ Type (including version number)
- ☞ Serial number and year of production
- ☞ Number of the certificate (EC prototype certificate-no.)
- ☞ EN number
- ☞ The specific mark for prevention of explosions in connection with the mark indicating the group of devices II, and the letter "G" (for areas where explosive gas, vapour, air mixtures are available)
- ☞ Explosion group
- ☞ The CE mark with the number of the indicated inspection authority, which act during production
- ☞ Set-up pressure for pressure valve
- ☞ Opening pressure
- ☞ Volume flow at opening pressure

The flame arrester is marked on the outer body of the pipe socket, as follows: BS&B-2x0,5

The metal foil is marked at the outermost wound element, as follows:

1. name of the manufacturer
  2. gap width
  3. material number
  4. direction of winding
- example: BS&B – 0,5 – 1.4571 – R

### 4. Installation

The arrangement and the installation of the vent into the plant shall be done under observance of the rules applicable to the relevant range of use. Especially the instructions for accident prevention have to be observed. A vertical installation position of the vent has to be kept under any circumstances.

The vent is equipped with a flange adapter DN50 PN16 Form C or ANSI 150 RF. While flanging be careful that the sealing face is not damaged and that there is no foreign matter or grease between the flanges for no gap to the atmosphere can occur.

**The valve has to be included in the equipotential bonding of the vessel or plant.**

**To prevent transportation damage, the valve inserts have been secured with transportation safeguards, which must be removed as follows:**

- ☞ Opening cover (21) by loosening the wing screw (36)
- ☞ Loosing hexagon nut (24) and lift up the flame arrester(2)
- ☞ Remove transportation guard
- ☞ Remove the valve insert (15)
- ☞ Remove the marking strap
- ☞ Reassemble the valve insert (15) include checking for easy mobility and proper location on the guide bolt(18)
- ☞ Install flame arrester (2) and pull hexagon nuts (24) tight
- ☞ Swivel in cover (21) and screw in wing screw (36) in clamp (35)

**Always regard „Transportation guard page“!**

<b>Created By:</b>	<b>RMG</b>	<b>Date: 01.01.14</b>	<b>BS&amp;B FlameSAF Limited, Limerick, Ireland</b>
<b>Approved By:</b>	<b>VOH</b>	<b>Date: 15.07.19</b>	

	<b>Pressure vent 935 50/2x0.5</b>	<b>REV 1.0</b>
	<b>Instructions for operating and maintenance</b>	<b>Page 3/7</b>

## 5. Maintenance

The maintenance includes a periodic visual control of the flame arrester, especially of the metal foil elements with regard to contamination and appearance. The intervals for the maintenance works depend on the operating conditions and how the individual media tend to contamination. They are determined by the operator.

### Disassembling of flame arrester element and valve insert:

- ☞ Opening cover (21) by loosening the wing screw (36)
- ☞ Loosing hexagon nut (24) and lift up the flame arrester(2)
  - ☞ Cleaning as described below
  - ☞ Lift up valve insert
  - ☞ Check of valve seat (14) and insert (15) as described below
  - ☞ Assembling of valve insert, flame arrester element and cover in reverse order as described under 4.

### Cleaning / controlling of flame arrester element:

For purposes of cleaning, the flame arrester element must be uninstalled as described above:  
 In case of minor contamination the flame arrester element shall be blown up with compressed air or hot vapour.  
 In case of major contamination a flushing with a cleaning agent can be carried out. After cleaning all parts which had been wetted by a cleaning agent shall be blown dry.  
 During the cleaning works no mechanical modifications may be done on the flame arrester element or on the housing parts of the flame arrester.

On principle, the flame arrester element has to be replaced by a new one, if:

- ☞ a fire occurred at the flame arrester element;
- ☞ loosening or distortions in the structure of the metal foil elements can be recognized;
- ☞ corrosion damages at the metal foil elements have been detected;
- ☞ in case of strongly contaminated metal foil elements, even after cleaning, a residual contamination of more than 30 % of the free flow cross-section remained.

All works in connection with repair and replacement of components shall be executed only by trained and authorized skilled personnel.

### Cleaning / controlling of valve seat and valve insert:

During maintenance work, valve seats and valve discs have to be checked for contamination and damages as well. Disassembling and re-installing are to be performed as described under 4.  
 The valve seat must be examined in particular for intactness of the sealing surface. Damages to the valve seat are to be eliminated by expert grinding and smoothing.  
 Depending on the sealing system in use on the valve inserts, make sure that either the FEP-seal or the metallic sealing surface are not damaged. Damaged valve discs or seals must be replaced by new ones.  
 It is recommended to hold spare flame arrester elements and the respective seals ready for each vent.

In case of replacement of structural units only original BS&B spare parts listed in the spare parts list may be installed to ensure the required safety.

<b>Created By:</b>	<b>RMG</b>	<b>Date: 01.01.14</b>	<b>BS&amp;B FlameSAF Limited, Limerick, Ireland</b>
<b>Approved By:</b>	<b>VOH</b>	<b>Date: 15.07.19</b>	

	<b>Pressure vent</b> <b>935 50/2x0.5</b> <b>Instructions for operating and maintenance</b>	<b>REV 1.0</b>
		<b>Page 4/7</b>

## 6. Spare part list

Table : Spare part list of 935-50/2x0,5

Item No.	Description	Qty.	Material	Order-No.
2	Flame arrester element 2x0,5; incl. cover, assembled	1	NSt	FET15415210
15	pressure valve insert – FEP *	1	NSt/FEP	FET15415216
	pressure valve insert – Metal *	1	NSt	FET15415226
35	Clamp (acryl glass)	1	K	FET999941000
40	Condensate drain	1	NSt	FET992766000
	Condensate screw	1	NSt	215130500
41	Gasket ring A10*14	1	LM	504580700

\* Valve inserts without added weights

### Material marks

St ... steel	LM ... light metal	FPM ... Viton	FEP .. Fluoride plastic
NSt ... stainless steel	K ... plastic	NBR ... Perbunan(N)	PTFE .. Fluoride plastic

<b>Created By:</b>	<b>RMG</b>	<b>Date: 01.01.14</b>	<b>BS&amp;B FlameSAF Limited, Limerick, Ireland</b>
<b>Approved By:</b>	<b>VOH</b>	<b>Date: 15.07.19</b>	



**Pressure vent  
935 50/2x0.5  
Instructions for operating and maintenance**

**REV 1.0**

**Page 5/7**

**Assembly drawing 935-50/2x0,5**

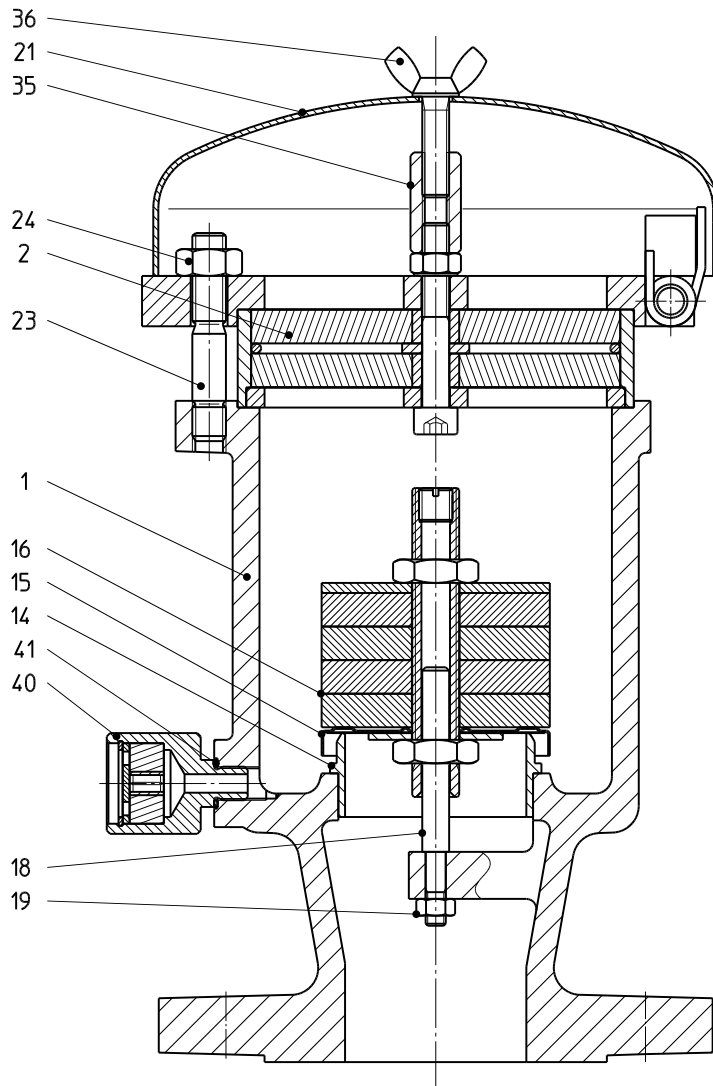

**nameplate**

<b>BS&amp;B FlameSaf</b>		<b>BS&amp;B</b>	
Raheen Business Park, Limerick, Ireland.			
<b>Flame Arrester ISO 16852</b>			
Type	935-50/2x0.5		Ex G IIA
Cert. No.	IBExU19ATEX2088 X		
Ser. No.	FSYYCCXXXXX	DN	50
Set Pressure		Opening Pressure	
Vacuum	-	mbar	-
Pressure	+ XX	mbar	XXX
Volume Flow Rate *		Volume Flow Rate *	
	-	m <sup>3</sup> /h	-
	XXX	m <sup>3</sup> /h	
* Air in standard conditions at opening pressure			

**Hazard Sign**

<b>Warning</b>			
Flame arrester have installation and application limits. Type design in accordance with ISO 16852			
DEF	$L_u/D = \text{---}$	BC: a	$t_{BT} = \text{--- min}$
	Ex G IIA	$T_0 = 60 \text{ } ^\circ\text{C}$	$p_0 = \text{atm.}$

**Warning Note**

Note: This flame arrester is safe for endurance burning! The use is restricted to pure hydrocarbons! Refer to operating and maintenance instructions!

<b>Created By:</b>	<b>RMG</b>	<b>Date:</b>	<b>01.01.14</b>	<b>BS&amp;B FlameSAF Limited, Limerick, Ireland</b>
<b>Approved By:</b>	<b>VOH</b>	<b>Date:</b>	<b>15.07.19</b>	