	Pressure and Vacuum Vent 945 200 Instructions for Operation and Maintenance	Rev. 2
		Page 1/7

This Instruction for Operation and Maintenance is applicable to the following products:

Size	Type	EU-Type Examination Certificate Number
DN200 / 8"	945 200	IBExU17ATEX1105 X

Table 1: Type Description

This IOM may also be accompanied by other data sheets with dimensions and pressure drop/volume flow rate diagram for consultation.

1. Use

The Pressure and Vacuum Vent 945 complies with the following standards:

EN ISO 80079-36:2016	Non-electrical equipment for potentially explosive atmospheres Basic methods and requirements
EN ISO 80079-37:2016	Non-electrical equipment for explosive atmospheres – Non-electrical type of protection constructional safety "c"

The general suitability as a pressure-vacuum vent for device group II, category 1/2 or EPL Ga/Gb when used with inflammable gas/air mixtures and vapour/air mixtures of inflammable liquids of explosion group IIB (standard gap width ≥ 0.5 mm) have been verified by tests executed at the Institute for Safety Technology IBExU GmbH Freiberg and the results are confirmed by the issued EU-Type Examination Certificate.

For pressure setting the following settings are available:

- Set-pressure for pressure: 2.5 up to 100 mbar *) *) factory pre-set default
- Set-pressure for vacuum: 2.5 up to 100 mbar *)
- Operating temperature: Surface temperature shall not exceed of the 80% of auto ignition temperature of the process media

The product internal temperature shall not exceed the 80% of the AIT of the process fluid and max surface temperature shall not exceed +450°C. The product is to be installed and operated in an environment with ambient temperature conditions (external temperatures between -20°C to +60°C).

As part of the documentation package, the product is delivered with a factory Test Certificate according to EN 10204, which includes the technical features of the product as well as the EU-type examination certificate number. Also, as part of the documentation package, a Declaration of Conformity is issued, assuring compliance with standards EN ISO 80079-36 / EN ISO 80079-37, as well as compliance with the ATEX directive 2014/34/EU.

2. Construction

The vent consists of a housing (1) with a Weatherhood for process discharge to the atmosphere. It is equipped with pressure (15) and vacuum (11) Pallets which control the set pressure and vacuum. The housing is sealed with one cover (3) using screws (6) and sealed with an O-ring (7). The Pallets are guided by guiding bushes screwed into the cover and Weatherhood.

For protection against the effects of weather, the vent is equipped with a Weatherhood (21) and protective mesh (2 & 14). This is clamped/mounted by guideposts (13) and cap nuts (24).

The Pallets are pre-set for the customer's specific set pressure via weighted disks.

The applied materials of the vent must be resistant under the respective operating conditions against mechanical and / or chemical effects and corrosion, so that the explosion protection is always maintained.

Where coatings are applied to the vent, said coatings do not exceed 2mm in combined thickness.

Created By:	T. Freitas	Date: 23/08/24	BS&B FlameSaf Limited, Limerick, Ireland
Approved By:	B. Murphy	Date: 23/08/24	



**Pressure and Vacuum Vent
945 200
Instructions for Operation and Maintenance**

Rev. 2

Page 2/7

3. Marking

The product is supplied with a nameplate (please refer to the last page) that provides important information to the customer about the product and its limitations. Below are some of the information provided:

Nameplate:

- Name and address of the Manufacturer
- Product Type (including element configuration)
- Serial Number and year of manufacture
- EU-type examination certificate number
- EN number
- EX mark, followed by the device group information II, category 1/2 and the letter “G” (for classified areas where explosive gases, vapors and/or air mixtures are present)
- Type of protection “c” (protection by constructional safety)
- CE mark, followed by the Notified Body number (2460)
- Set Pressure setting
- Volume flow values at opening pressure

Created By:	T. Freitas	Date: 23/08/24	BS&B FlameSaf Limited, Limerick, Ireland
Approved By:	B. Murphy	Date: 23/08/24	

4. Installation

The pipeline arrangement is defined by the customer, observing guidelines of relevant and applicable standards. The installation of the product shall be conducted by the customer following this IOM and applicable standards. The customer shall observe the requirements and limitations of use outlined on relevant standards. Accident prevention measures and risk assessment to take place before installation. Health and safety guidelines to be followed. The Vent shall only be installed in the Vertical-up orientation.

Customer shall maintain a safe clearance between the product and any other object/obstacle that may obstruct the unit venting area and may affect its flow capacity/performance. Customer shall evaluate operating conditions and establish a safe clearance distance.

Before installation, the customer must make sure the sealing surfaces are in perfect condition and free from any foreign objects, oil, or grease. Appropriate gaskets and torque shall be applied for a proper and leak tight installation.

For flanges with flat sealing faces it is recommended to use flat-ring gaskets with suitable specification for the connecting flanges and process fluid media. BS&B recommends the use of low stress gaskets (DIN 2501 $k_D \leq 25b_D$) such as compressed fibre gaskets (e.g., KLINGERSIL® C-4400 or technically equivalent). A low stress spiral wound gaskets (e.g., Flexitallic® Style CGI or technically equivalent) can also be used. Before installation, customer must make sure the sealing surfaces are in perfect condition and free from any foreign objects, oil, or grease. Appropriate gaskets and torque shall be applied for a proper and leak tight installation. After installation and before operation it is recommended that the customer performs a leak tightness test at the connections to assure leak tightness. The product must not be pressurized with more than 2 BARG.

The Vent must be included in the equipotential bonding of the vessel and/or the plant.

The product shall be lifted by the provided Lifting Eyes, as illustrated in Figure 1.

WARNING: Never apply shear tension to Lifting Eyes.

Before lifting, make sure the Lifting Eyes are aligned, properly screwed and with their shoulder/base fully seated at the surface.

Caution: The product is provided with two lifting eyes attached to the Weatherhood (21) and two lifting eyes attached to the Cover (3). The product shall never be solely lifted by the Weatherhood Lifting Eyes, only by the Cover lifting eyes. The Weatherhood Lifting Eyes shall only be used to aid in the balancing and alignment of the product during the lifting.

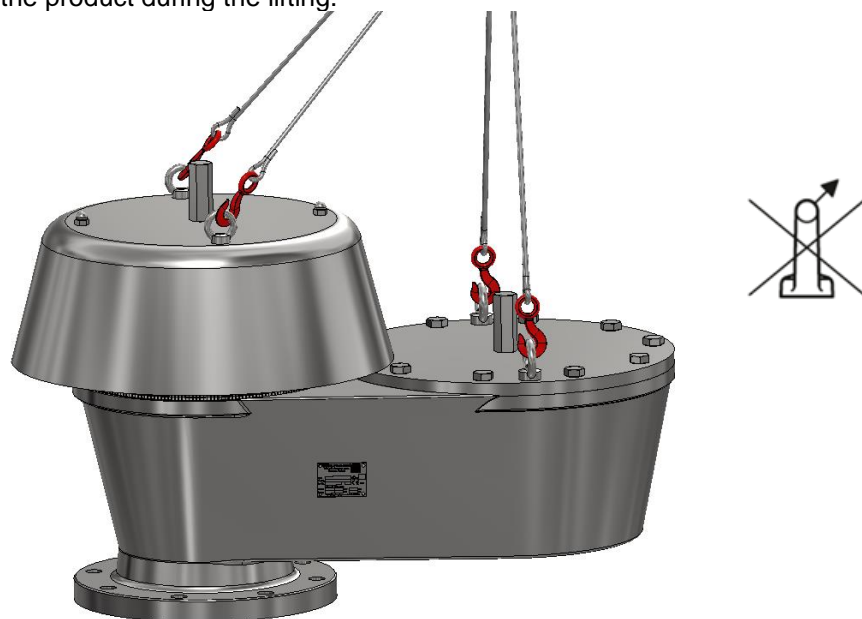

Figure 1 – Lifting

Created By:	T. Freitas	Date: 23/08/24	BS&B FlameSaf Limited, Limerick, Ireland
Approved By:	B. Murphy	Date: 23/08/24	

To prevent transportation damage, the Pallets are shipped separate from the vent and need to be assembled in the Vent before operation.

The Pallets are individually packed and marked with the product serial number and a note identifying if that pallet is for the positive pressure side (P) or for the vacuum side (V).

Pressure Side Pallet (P) is item 15 of the drawing, and the Vacuum Side Pallet (V) is item 11 of the drawing (please refer to the Identification of Parts Figure).

Note: Pallets with heavy weights may be provided with lifting lugs to facilitate their handling and installation, as shown in Figure 2.

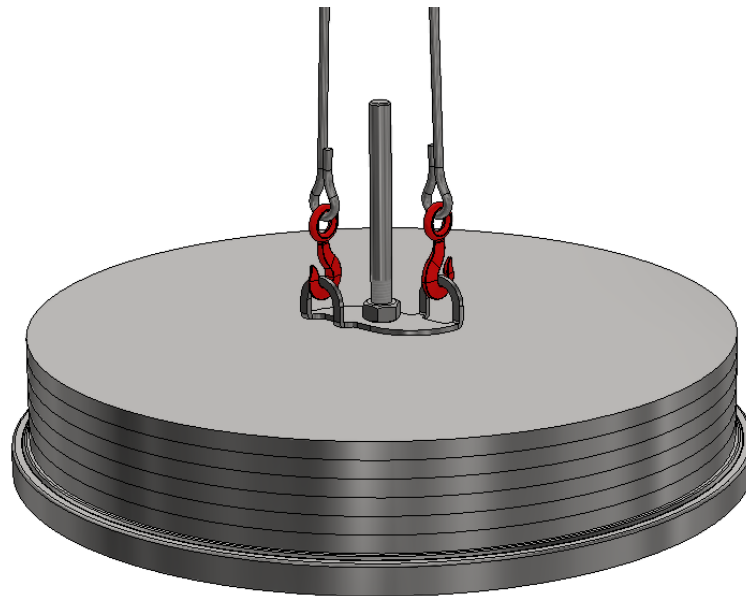

Figure 2 – Pallet fitted with Lifting Lugs

Pallets shall be installed as per the following steps:

- Remove the Cover (3) and Weatherhood (21) by removing their Screws (6) and Nuts (24) and lifting it.
Note: The Cover may be provided with threaded holes where the user can install lifting eyes to facilitate the removal of the Cover, but these lifting eyes shall not be used on their own to lift the complete unit/product.
- Install the Pallets carefully on top of the Pressure and Vacuum seats (2 & 10), at this sequence
- Replace the Cover (3) and Weatherhood (21), making sure that the guiding rod of the Pressure and Vacuum Pallets are properly inserted and guided inside the Guide Bush (4 and 12)
- Tighten the Cover Screws (6) and Nuts (24)

5. Maintenance

The product must be periodically maintained, maintenance recommendations include a periodic visual inspection of the Emergency Vent with regards to contamination and appearance. The intervals for the maintenance works depend on the operating conditions and how aggressive and contaminating the process media is. The maintenance/inspection frequency must be established by the customer/end user.

In case of major contamination of process residues to the Pressure Pallet and Seat, a cleaning process can be conducted to the affected parts with non-aggressive materials (clothes, brushes etc) and using appropriate cleaning agents/detergent which must be suitable for the materials of the parts being clean and must not corrode or damage any of the product components in anyway. After rinsing and completion of cleaning, all parts shall be

Created By:	T. Freitas	Date: 23/08/24	BS&B FlameSaf Limited, Limerick, Ireland
Approved By:	B. Murphy	Date: 23/08/24	



**Pressure and Vacuum Vent
945 200
Instructions for Operation and Maintenance**

Rev. 2

Page 5/7

blown dry with clean compressed air. No mechanical modifications may be made to any of the parts of the Emergency Vent. The product must not be modified in any way.

All work in connection with maintenance and replacement of components shall be executed only by qualified and trained personnel.

Seat and Pressure Pallet shall be periodically checked against contamination and/or damage. If any damage or imperfection to the Seat is found it may be repaired with professional polishing or lapping equipment.

The main seal in the Pressure Pallet should also be checked and if any damage or imperfections are found it must be replaced by a new one.

The sequence for mounting and dismounting parts shall be performed according to instructions of section 4.

It is recommended to always keep spare parts in stock for maintenance.

Only genuine parts, supplied by BS&B FlameSaf Ltd, may be used for any maintenance/repair work performed on the Flame Arrester. Please refer to the Spare Parts List for the part numbers to be used to re-order parts.

During the maintenance works no mechanical modification may be done to any parts of the Pressure and Vacuum Vent without BS&B FlameSaf Ltd written approval.

All maintenance works on the product shall only be performed by qualified and trained personnel.

After finishing maintenance works and before operation it is recommended that the customer performs a leak tightness test to assure leak tightness

Only genuine parts, supplied by BS&B FlameSaf Ltd, may be used for any maintenance/repair work performed on the product. Please refer to Table 2 (Spare Parts List) for the part numbers to be used to re-order parts.

Created By:	T. Freitas	Date: 23/08/24	BS&B FlameSaf Limited, Limerick, Ireland
Approved By:	B. Murphy	Date: 23/08/24	



6. Spare Parts List

Item No	Designation	Qty per Vent	Material	Order / Part Number
3	Cover	1	CS	999678900
3	Cover	1	SS	842082421
4	Guide Bush - Pressure Side	1	SS	182056200
6	Cover Bolts	10	CS	220009201
6	Cover Bolts	10	SS	220009200
7	Cover Seal	1	NBR	802070800
			FPM (Viton)	802071600
			EPDM	802072400
			FEP Encap.	802073200
8	Guide Bush - Vacuum Side	1	SS	182056200
11	Vacuum Pallet Assy **	1	SS/PTFE	960000841
	Vacuum Pallet	1	SS	812072500
	Vacuum Pallet Seal	1	PTFE	722089000
15	Pressure Pallet **	1	SS/PTFE	960000841
	Pressure Pallet	1	SS	812072500
	Pressure Pallet Seal	1	PTFE	722089000

Table 2: Spare parts List

Notes:

- * Essential parts for periodic preventive maintenance
- ** Pressure and Vacuum Pallets are supplied without calibration weights. Part numbers listed are for standard Pallet Assy with PTFE seal.
- CS = Carbon Steel
- SS = Stainless Steel

Created By:	T. Freitas	Date: 23/08/24	BS&B FlameSaf Limited, Limerick, Ireland
Approved By:	B. Murphy	Date: 23/08/24	

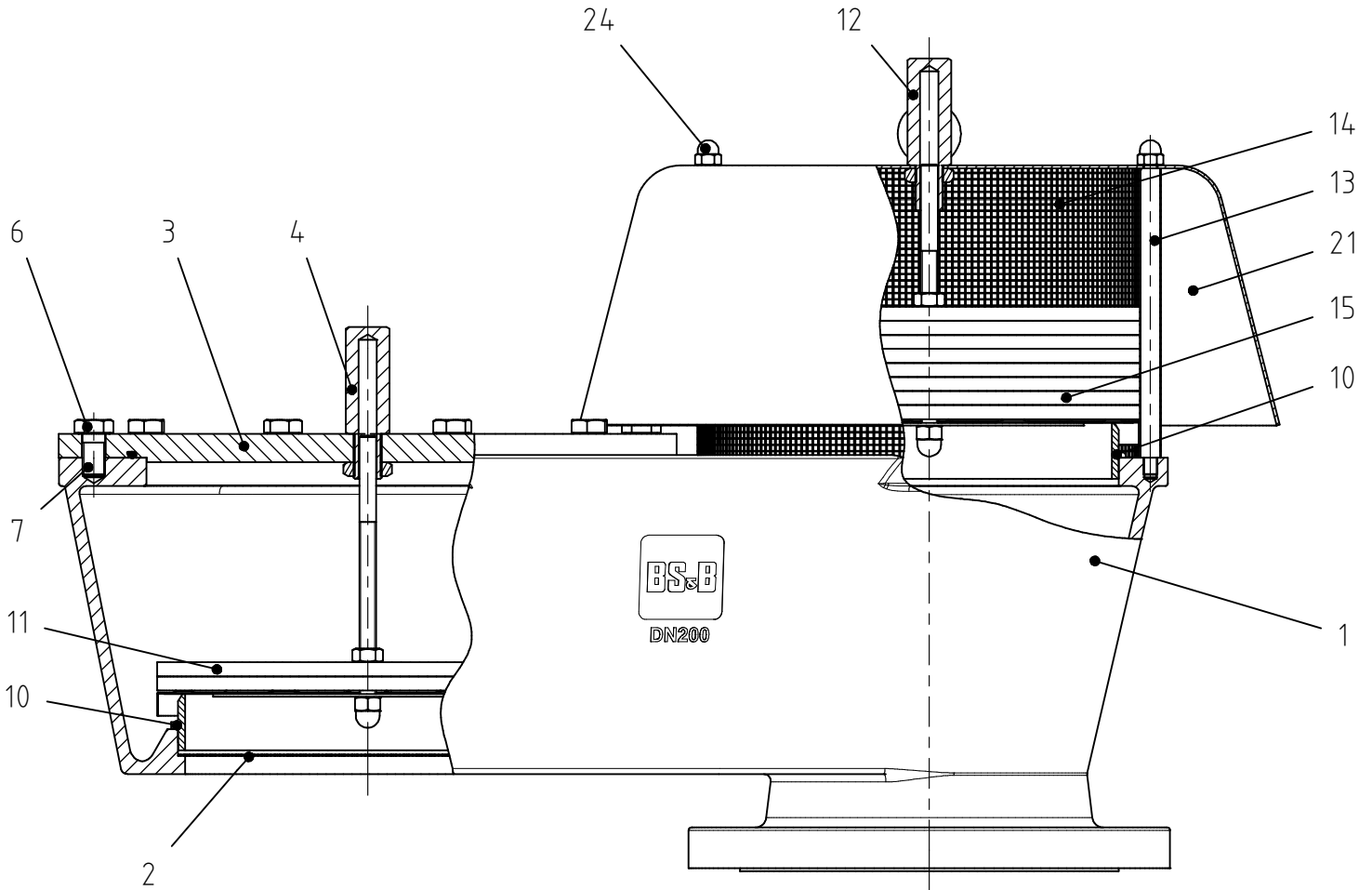

Nameplate

Figure 3 - Identification of Parts

Created By:	T. Freitas	Date: 23/08/24	BS&B FlameSaf Limited, Limerick, Ireland
Approved By:	B. Murphy	Date: 23/08/24	